

sinamics

SINAMICS S120
Synchronous Motors
1FK7

SIEMENS

SIEMENS

SINAMICS

SINAMICS S120 1FK7 SINAMICS Synchronous Motors

Configuration Manual

Foreword

Motor Description

1

Electrical Connections

2

Technical Data and Speed-
Torque Diagrams

3

Motor Components (Options)

4

Dimension Drawings

5

Appendix

A

(PFK7S), Edition 12.2004

6SN1197-0AD16-0BP0

Safety Guidelines

This manual contains notices you have to observe in order to ensure your personal safety, as well as to prevent damage to property. The notices referring to your personal safety are highlighted in the manual by a safety alert symbol, notices referring to property damage only have no safety alert symbol. These notices shown below are graded according to the degree of danger.



Danger

indicates that death or severe personal injury **will** result if proper precautions are not taken.



Warning

indicates that death or severe personal injury **may** result if proper precautions are not taken.



Caution

with a safety alert symbol, indicates that minor personal injury can result if proper precautions are not taken.

Caution

without a safety alert symbol, indicates that property damage can result if proper precautions are not taken.

Notice

indicates that an unintended result or situation can occur if the corresponding information is not taken into account.

If more than one degree of danger is present, the warning notice representing the highest degree of danger will be used. A notice warning of injury to persons with a safety alert symbol may also include a warning relating to property damage.

Qualified Personnel

The device/system may only be set up and used in conjunction with this documentation. Commissioning and operation of a device/system may only be performed by **qualified personnel**. Within the context of the safety notes in this documentation qualified persons are defined as persons who are authorized to commission, ground and label devices, systems and circuits in accordance with established safety practices and standards.

Prescribed Usage

Note the following:



Warning

This device may only be used for the applications described in the catalog or the technical description and only in connection with devices or components from other manufacturers which have been approved or recommended by Siemens. Correct, reliable operation of the product requires proper transport, storage, positioning and assembly as well as careful operation and maintenance.

Trademarks

All names identified by ® are registered trademarks of the Siemens AG. The remaining trademarks in this publication may be trademarks whose use by third parties for their own purposes could violate the rights of the owner.

Copyright Siemens AG 2004. All rights reserved.

Disclaimer of Liability

We have reviewed the contents of this publication to ensure consistency with the hardware and software described. Since variance cannot be precluded entirely, we cannot guarantee full consistency. However, the information in this publication is reviewed regularly and any necessary corrections are included in subsequent editions.

Siemens AG
Automation and Drives
Postfach 4848, 90327 Nuremberg, Germany

Siemens AG 2004
Technical data subject to change

Designation of the documentation

Printing history

Brief details of this edition and previous editions are listed below.

The status of each edition is shown by the code in the "Remarks" column.

Status code in the "Remarks" column:

- A** New documentation
- B** Unrevised reprint with new Order No.
- C** Revised edition with new status

If factual changes have been made on the page since the last edition, this is indicated by a new edition coding in the header on that page.

Edition	Order No. for 1FK7	Remarks
12.04	6SN1197-0AD16-0BP0	A

Trademarks

SINAMICS®, SIMOTION®, SIMATIC®, SIMATIC HMI®, SIMATIC NET®, SIROTEC®, SINUMERIK®, SIMODRIVE®, SIEMOSYN®, SIMOVERT MASTERDRIVES® and MOTION-CONNECT® are registered trademarks of Siemens AG. Other names in this publication might be trademarks whose use by a third party for his own purposes may violate the rights of the registered holder.

Further information is available on the Internet under:
<http://www.siemens.com/motioncontrol>

This publication was produced with SIPS+

The control system may support functions that are not described in this documentation. However, no claim can be made regarding the availability of these functions when the equipment is first supplied or in the event of servicing.

We have checked that the contents of this document correspond to the hardware and software described. Nonetheless, differences might exist and therefore we cannot guarantee that they are completely identical. The information given in this publication is reviewed at regular intervals and any corrections that might be necessary are made in the subsequent printings. Suggestions for improvement are also welcome.

© Siemens AG 2004. All rights reserved.

Order No. 6SN1197-0AD16-0BP0
Printed in the Federal Republic of Germany

We reserve the right to make technical changes.
Siemens-Aktiengesellschaft

Danger and warning information



Danger

Start-up/commissioning is absolutely prohibited until it has been completely ensured that the machine, in which the components described here are to be installed, is in full compliance with the specifications of Directive 98/37/EC.

SINAMICS devices and synchronous motors may only be commissioned by suitably qualified personnel.

This personnel must carefully observe the technical customer documentation associated with this product and be knowledgeable about and carefully observe the danger and warning information.

Operational electrical equipment and motors have parts and components which are at hazardous voltage levels.

When the machine or system is operated, hazardous axis movements can occur.

All of the work carried-out on the electrical machine or system must be carried-out with it in a no-voltage condition.

SINAMICS drive units are designed for operation on low-ohmic, grounded line supply systems (TN line supply systems).



Warning

The successful and safe operation of this equipment and motors is dependent on professional transport, storage, installation and mounting as well as careful operator control, service and maintenance.

For special versions of the drive units and motors, information and data in the catalogs and quotations additionally apply.

In addition to the danger and warning information/instructions in the technical customer documentation supplied, the applicable domestic, local and plant-specific regulations and requirements must be carefully taken into account.



Caution

The motors can have surface temperatures of over +80 °C.

This is the reason that temperature-sensitive components, e.g. cables or electronic components may neither be in contact nor be attached to the motor.

When connecting-up cables, please observe that they

- are not damaged
 - are not subject to tensile stress
 - cannot be touched by rotating components.
-



Caution

The DRIVE-CLiQ interface contains motor and encoder-specific data as well as an electronic rating plate. This is the reason that this Sensor Module may only be operated on the original motor - and may not be mounted onto other motors or replaced by a sensor module from other motors.

The DRIVE-CLiQ interface has direct contact to components that can be damaged/destroyed by electrostatic discharge (ESDS). Neither hands nor tools that could be electrostatically charged may come into contact with the connections.

Caution

SINAMICS drive units with synchronous motors are subject, as part of the routine test, to a voltage test in accordance with EN 50178. While the electrical equipment of industrial machines is being subject to a voltage test in accordance with EN60204-1, Section 19.4, all SINAMICS drive unit connections must be disconnected/withdrawn in order to avoid damaging the SINAMICS drive units.

Motors should be connected-up according to the circuit diagram provided. It is not permissible to directly connect the motors to the three-phase line supply. Motors will be destroyed if they are connected directly to the three-phase line supply.

Note

SINAMICS units with synchronous motors fulfill, when operational and in dry operating rooms, the Low-Voltage Directive 73/23/EEC.

SINAMICS units with synchronous motors fulfill, in the configuration specified in the associated EC Declaration of Conformity, the EMC Directive 89/336/EEC.

ESDS instructions



Caution

ElectroStatic-Sensitive Devices (ESDS) are individual components, integrated circuits, or modules that can be damaged by electrostatic fields or discharges.

ESDS regulations for handling boards and equipment:

When handling components that can be destroyed by electrostatic discharge, it must be ensured that personnel, the workstation and packaging are well grounded!

Personnel in ESD zones with conductive floors may only touch electronic components if they are

- grounded through an ESDS bracelet and
- wearing ESDS shoes or ESDS shoe grounding strips.

Electronic boards may only be touched when absolutely necessary.

Electronic boards may not be brought into contact with plastics and articles of clothing manufactured from man-made fibers.

Electronic boards may only be placed on conductive surfaces (table with ESDS surface, conductive ESDS foam rubber, ESDS packing bag, ESDS transport containers).

Electronic boards may not be brought close to data terminals, monitors or television sets. Minimum clearance to screens > 10 cm).

Measurements may only be carried-out on electronic boards and modules if

- the measuring instrument is grounded (e.g. via a protective conductor) or
 - before making measurements with a potential-free measuring device, the measuring head is briefly discharged (e.g. by touching an unpainted blank piece of metal on the control cabinet).
-

Standards, regulations

The appropriate standards, regulations are directly assigned to the functional requirements.

Table of Contents

	Foreword	iii
1	Motor Description	1-1
1.1	Features	1-1
1.2	Technical	1-2
1.3	Order designation	1-4
1.3.1	1FK7 Compact motors - core type, non-ventilated	1-4
1.3.2	1FK7 High Dynamic motors - core type, non-ventilated	1-6
1.4	Armature short-circuit braking	1-8
1.5	Coupling	1-10
2	Electrical Connections	2-1
2.1	Connection overview	2-1
2.2	Power connection	2-2
2.3	DRIVE-CLiQ	2-3
2.4	Motors with DRIVE-CLiQ	2-3
2.5	Motors without DRIVE-CLiQ	2-4
2.6	Rotating the connector at the motor	2-4
3	Technical Data and Speed-Torque Diagrams	3-1
3.1	Introduction	3-1
3.2	Speed-torque diagrams 1FK7 CT	3-2
3.3	Speed-torque diagrams 1FK7 HD	3-26
3.4	Cantilever force diagrams	3-40
3.5	Axial forces	3-44
4	Motor Components (Options)	4-1
4.1	Thermal motor protection	4-1
4.2	Encoders	4-3
4.2.1	Encoder overview	4-3
4.3	Motors with DRIVE-CLiQ	4-4
4.4	Motors without DRIVE-CLiQ	4-5
4.4.1	Incremental encoders	4-5
4.4.2	Absolute value encoder	4-8
4.4.3	Resolvers	4-10
4.5	Holding brake (option)	4-12
4.6	Planetary gearbox (option)	4-13

5	Dimension Drawings	5-1
5.1	Introduction	5-1
5.2	1FK7 CT with DRIVE-CLiQ.....	5-2
5.3	1FK7 HD with DRIVE-CLiQ.....	5-10
5.4	1FK7 CT without DRIVE-CLiQ.....	5-14
5.5	1FK7 HD without DRIVE-CLiQ	5-22
A	Appendix	A-1
A.1	References	A-1
	Index	

Tables

Table 1	Configuration Manual, individual sections	iii
Table 1-1	Technical data, 1FK7 motor	1-2
Table 1-2	Resistor braking for 1FK7 CT and 1FK7 HD	1-9
Table 1-3	Assignment of the coupling outputs to the motors	1-10
Table 2-1	Direction of rotation and torques when rotating the connector	2-5
Table 3-1	1FK7022 CT	3-2
Table 3-2	1FK7032 CT	3-4
Table 3-3	1FK7040 CT	3-6
Table 3-4	1FK7042 CT	3-8
Table 3-5	1FK7060 CT	3-10
Table 3-6	1FK7063 CT	3-12
Table 3-7	1FK7080 CT	3-14
Table 3-8	1FK7083 CT	3-16
Table 3-9	1FK7100 CT	3-18
Table 3-10	1FK7101 CT	3-20
Table 3-11	1FK7103 CT	3-22
Table 3-12	1FK7105 CT	3-24
Table 3-13	1FK7033 HD	3-26
Table 3-14	1FK7043 HD	3-28
Table 3-15	1FK7044 HD	3-30
Table 3-16	1FK7061 HD	3-32
Table 3-17	1FK7064 HD	3-34
Table 3-18	1FK7082 HD	3-36
Table 3-19	1FK7085 HD	3-38
Table 3-20	Explanation of the formula abbreviations	3-40
Table 4-1	Features and technical data	4-1
Table 4-2	Encoder for motor with and without DRIVE-CLiQ	4-3
Table 4-3	Prefabricated cable	4-4
Table 4-4	Technical data, incremental encoders sin/cos 1Vpp	4-5
Table 4-5	Connection assignment for 17-pin flange-mounted socket	4-7
Table 4-6	Prefabricated cable	4-7
Table 4-7	Technical data, absolute value encoder	4-8
Table 4-8	Connection assignment for 17-pin flange-mounted socket	4-9
Table 4-9	Prefabricated cable	4-9
Table 4-10	Technical data, resolvers	4-10

Table of Contents

Table 4-11	Connection assignment for 12-pin flange-mounted socket.....	4-11
Table 4-12	Prefabricated cable	4-11
Table 4-13	Technical data of the holding brakes used for 1FK7 motors	4-12
Table 4-14	Technical data of the planetary gearboxes which can be used for 1FK7 CT and 1FK7 HD motors	4-13
Table 4-15	Continuous duty S1	4-14
Table 4-16	Dimensions 1FK7 CT motor with planetary gearbox	4-15
Table 4-17	Dimensions 1FK7 CT motor with planetary gearbox	4-15
Table 4-18	Dimensions 1FK7 HD motor with planetary gearbox.....	4-16
Table 4-19	Dimensions 1FK7 HD motor with planetary gearbox.....	4-16

Motor Description

1.1 Features

Overview

1FK7 motors are extremely compact permanent-magnet synchronous motors. The available options, gear units and encoders, together with the expanded product range, mean that the 1FK7 motors can be optimally adapted to any application. They therefore also satisfy the permanently increasing demands of state-of-the-art machine generations.

1FK7 motors can be combined with the SINAMICS S120 drive system to create a powerful system with high functionality. The integrated encoder systems for speed and position control can be selected depending on the application.

The motors are designed for operation without external cooling and the heat is dissipated through the motor surface. 1FK7 motors have a high overload capability.



Figure 1-1 1FK7 motors

Benefits

1FK7 Compact motors offer:

- Space-saving installation thanks to extremely high power/weight ratio
- Can be universally used for many applications
- Wide range of motors

1FK7 High Dynamic motors offer:

- Extremely high dynamic response thanks to low rotor moment of inertia

Fields of application

- Machine tools
- Robots and handling systems
- Wood, glass, ceramics and stone working
- Packaging, plastics and textile machines
- Auxiliary axes

1.2 Technical data

Table 1-1 Technical data, 1FK7 motor

Type of motor	Permanent-magnet synchronous motor
Magnet material	Rare-earth magnetic material
Insulation of the stator winding in accordance with EN 60034-1 (IEC 60034-1)	Temperature class F for a winding temperature of $\Delta T = 100 \text{ K}$ at an ambient temperature of $+40 \text{ }^\circ\text{C}$
Type of construction according to EN 60034-7 (IEC 60034-7)	IM B5 (IM V1, IM V3)
Degree of protection according to EN 60034-5 (IEC 60034-5)	IP64
Cooling	Non-ventilated
Temperature monitoring	KTY 84 temperature sensor in the stator winding
Drive shaft end in accordance with DIN 748-3 (IEC 60072-1)	Plain shaft (no keyway)
Paint finish	Unpainted
2. Rating plate 3rd rating plate	glued into the bearing endshield supplied loose
Radial eccentricity, concentricity, and axial eccentricity in accordance with DIN 42955 (IEC 60072-1)	Tolerance N (normal)
Vibration severity according to EN 60034-14 (IEC 60034-14)	Grade N (normal)

Sound pressure level, max. acc. to DIN EN ISO 1680	1FK702: 55 dB (A) 1FK703: 55 dB (A) 1FK704: 55 dB (A) 1FK706: 65 dB (A) 1FK708: 70 dB (A) 1FK710: 70 dB (A)
Encoder systems, integrated for motors with/without DRIVE-CLiQ interface	<ul style="list-style-type: none"> • Incremental encoder sin/cos 1 V_{pp} 2048 pulses/revolution • Absolute encoder ²⁾, multiturn, 2048 pulses/revolution with 1FK704 to 1FK710. 512 pulses/revolution with 1FK702 and 1FK703 and traversing range 4096 rev. with EnDat interface • Simple absolute encoder ²⁾, multiturn, 32 S/R and traversing range 4096 rev. with EnDat interface • Resolver multi-pole ¹⁾ (number of poles corresponds to number of pole pairs of the motor) • Resolver 2-pole
Connection	Connectors for signals and power can be rotated (270°)
Options	<ul style="list-style-type: none"> • Drive shaft end with fitted key and keyway (half-key balancing) • Integrated holding brake • Degree of protection IP65, additional IP67 drive end flange • Planetary gear unit (requires: plain shaft end (no keyway)) • Paint finish, anthracite

¹⁾ For SINAMICS the max. operating frequency is 470 Hz - and this must be carefully observed.

²⁾ When using an absolute value encoder the rated torque is reduced by 10%

1.3 Order designation

1.3.1 1FK7 Compact motors - core type, non-ventilated

Selection/Ordering data

Rated speed	Shaft height SH	Rated power	Standstill torque	Rated torque ¹⁾	Rated current	1FK7 synchronous motor Compact Non-ventilated	Pole pair No.	Rotor moment of inertia (without brake)	Weight (without brake)
n_N	h	P_N With $\Delta T=100$ K	M_0 With $\Delta T=100$ K	M_N With $\Delta T=100$ K	I_N With $\Delta T=100$ K	Order No. Core type		J	m
RPM	mm	kW	Nm	Nm	A			10^{-4} kgm ²	kg
2000	100	7.75	48	37	16	1FK7 105 - 5AC71- 1 7 7 7	4	156	39
3000	48	0.823		2.6	1.95	1FK7 042 - 5AF71- 1 7 7 7	4	3.01	4.9
	63	1.48	6	4.7	3.7	1FK7 060 - 5AF71- 1 7 7 7	4	7.95	7
		2.29	11	7.3	5.6	1FK7 063 - 5AF71- 1 7 7 7	4	15.1	11.5
	80	2.14	8	6.8	4.4	1FK7 080 - 5AF71- 1 7 7 7	4	15	10
		3.3	16	10.5	7.4	1FK7 083 - 5AF71- 1 7 7 7	4	27.3	14
4500	100	3.77	18	12	8	1FK7 100 - 5AF71- 1 7 7 7	4	55.3	19
		4.87	27	15.5	11.8	1FK7 101 - 5AF71- 1 7 7 7	4	79.9	21
	5.37 ⁴⁾	36	20.5 ⁴⁾	16.5 ⁴⁾	1FK7 103 - 5AF71- 1 7 7 7	4	105	29	
	8.17	48	26	18	1FK7 105 - 5AF71- 1 7 7 7	4	156	39	
	63	1.74	6	3.7	4.1	1FK7 060 - 5AH71- 1 7 7 7	4	7.95	7
2.09 ⁵⁾		11	5 ⁵⁾	6.1 ⁵⁾	1FK7 063 - 5AH71- 1 7 7 7	4	15.1	11.5	
2.39		8	5.7	5.6	1FK7 080 - 5AH71- 1 7 7 7	4	15	10	
80	3.04 ⁶⁾	16	8.3 ⁶⁾	9 ⁶⁾	1FK7 083 - 5AH71- 1 7 7 7	4	27.3	14	
	6000	0.4	0.85	0.6	1.4	1FK7 022 - 5AK71- 1 7 7 7	3	0.28	1.8
36		0.5	1.1	0.8	1.4	1FK7 032 - 5AK71- 1 7 7 7	3	0.61	2.7
48		0.69	1.6	1.1	1.7	1FK7 040 - 5AK71- 1 7 7 7	4	1.69	3.5
	1.02 ⁷⁾	3	2 ⁷⁾	3.1 ⁷⁾	1FK7 042 - 5AK71- 1 7 7 7	4	3.01	4.9	
•Encoder systems for motors without DRIVE-CLiQ interface:			Incremental encoder sin/cos 1 V _{pp} 2048 S/R Absolute value encoder EnDat 2048 pulses/rev ^{1) 2)} Absolute value encoder EnDat 512 pulses/rev ^{1) 3)} Single absolute value encoder EnDat 32 pulses/rev ^{1) 2)} Multi-pole resolver ¹⁰⁾ Resolver 2-pole			A E H G S T			
•Encoder systems for motors with DRIVE-CLiQ interface:			Incremental encoder sin/cos 1 V _{pp} 2048 pulses/rev Absolute value encoder EnDat 2048 pulses/rev ^{1) 2)} Absolute value encoder EnDat 512 pulses/rev ^{1) 3)} Single absolute value encoder EnDat 32 pulses/rev ¹⁾ Multi-pole resolver ¹⁰⁾ Resolver 2-pole			D F L K B			
•Shaft end: with fitted key and keyway with fitted key and keyway Smooth shaft Smooth shaft			Tolerance: N N N N		Holding brake: without with without with		A B G H		
•Degree of protection:			IP64 IP65 and additional IP67 drive end flange IP64, anthracite paint finish IP65 and additional drive end flange IP67, anthracite paint finish IP65 and additional drive end flange IP67, anthracite paint finish and metal rating plate on the motor			0 2 3 5 8			

Selection/Ordering data

Motor type (continued)	Stall current I_0 With M_0 $\Delta T=100$ K A	Calculated Power $P_{calc} =$ $M_0 \times n_N / 9550$ P_{calc} for M_0 $\Delta T=100$ K kW	SINAMICS motor module Rated output current		Power cable with complete shield Motor terminals (and brake terminals) via Power supply connector		
			I_N With M_0 $\Delta T=100$ K A	Order No.	Power connector Size	Cable cross-section Motor ⁹⁾ mm ²	Order No. Prefabricated cable
1FK7 105 - 5AC71...	20	10	30	6SL3 120- 7 TE23 - 0AA0	1.5	4 x 2.5	6FX7 002- 5 7 S31 - 7 7 7 0
1FK7 042 - 5AF71...	2.2	0.9	3	- 7 TE13 - 0AA0	1	4 x 1.5	- 5 7 S01 - 7 7 7 0
1FK7 060 - 5AF71...	4.5	1.9	5	- 7 TE15 - 0AA0	1	4 x 1.5	- 5 7 S01 - 7 7 7 0
1FK7 063 - 5AF71...	8	3.5	9	- 7 TE21 - 0AA0	1	4 x 1.5	- 5 7 S01 - 7 7 7 0
1FK7 080 - 5AF71...	4.8	2.5	5	- 7 TE15 - 0AA0	1	4 x 1.5	- 5 7 S01 - 7 7 7 0
1FK7 083 - 5AF71...	10.4	5.0	9 ⁸⁾	- 7 TE21 - 0AA0	1	4 x 1.5	- 5 7 S01 - 7 7 7 0
1FK7 100 - 5AF71...	11.2	5.7	18	- 7 TE21 - 8AA0	1	4 x 1.5	- 5 7 S01 - 7 7 7 0
1FK7 101 - 5AF71...	19	8.5	18 ⁸⁾	- 7 TE21 - 8AA0	1.5	4 x 2.5	- 5 7 S31 - 7 7 7 0
1FK7 103 - 5AF71...	27.5	11.3	30	- 1 TE23 - 0AA0	1.5	4 x 4	- 5 7 S41 - 7 7 7 0
1FK7 105 - 5AF71...	31	15	30 ⁸⁾	- 7 TE23 - 0AA0	1.5	4 x 10	- 5 7 S61 - 7 7 7 0
1FK7 060 - 5AH71...	6.2	2.8	9	- 7 TE21 - 0AA0	1	4 x 1.5	- 5 7 S01 - 7 7 7 0
1FK7 063 - 5AH71...	12	5.2	18	- 7 TE21 - 8AA0	1	4 x 1.5	- 5 7 S01 - 7 7 7 0
1FK7 080 - 5AH71...	7.4	3.8	9	- 7 TE21 - 0AA0	1	4 x 1.5	- 5 7 S01 - 7 7 7 0
1FK7 083 - 5AH71...	15	7.5	18	- 7 TE21 - 8AA0	1	4 x 1.5	- 5 7 S01 - 7 7 7 0
1FK7 022 - 5AK71...	1.8	0.5	3	- 7 TE13 - 0AA0	1	4 x 1.5	- 5 7 S01 - 7 7 7 0
1FK7 032 - 5AK71...	1.7	0.7	3	- 7 TE13 - 0AA0	1	4 x 1.5	- 5 7 S01 - 7 7 7 0
1FK7 040 - 5AK71...	2.25	1.0	3	- 7 TE13 - 0AA0	1	4 x 1.5	- 5 7 S01 - 7 7 7 0
1FK7 042 - 5AK71...	4.4	1.9	5	- 7 TE15 - 0AA0	1	4 x 1.5	- 5 7 S01 - 7 7 7 0
•Single Motor Module				1			
•Double Motor Module				2			
Type of power cable							
•MOTION-CONNECT 800						8	
•MOTION-CONNECT 500						5	
•without brake conductors							C
•with brake conductors							D
Length code as well as power and signal cables, refer to Catalog, Chapter "MOTION-CONNECT connection systems".							

- 1) When using the absolute value encoder, M_N is reduced by 10%.
- 2) Not possible for 1FK702 and 1FK703.
- 3) Only possible for 1FK702 and 1FK703.
- 4) Rated power/current based on $n = 2500$ RPM
- 5) Rated power/current based on $n = 4000$ RPM
- 6) Rated power/current based on $n = 3500$ RPM
- 7) Rated power/current based on $n = 5000$ RPM
- 8) With the specified motor module, the motor cannot be fully utilized according to $\Delta T = 100$ K winding temperature rise. If a larger motor module is used, then it must be carefully checked as to whether the specified power cable can be connected to the larger motor module.
- 9) The current carrying capacity of the power cables corresponds to IEC 60204-1 for routing type C under continuous operating conditions in an air ambient temperature of +40 °C, designed/dimensioned for I_0 (100 K), cables with PVC/PUR insulation.
- 10) For SINAMICS S120 a max. operating frequency of 470 Hz must be carefully maintained.

1.3.2 1FK7 High Dynamic motors - core type, non-ventilated

Selection/Ordering data

Rated speed	Shaft height SH	Rated power	Stall torque	Rated torque ¹⁾	Rated current	Synchronous motor 1FK7 High Dynamic Non-ventilated	Pole pair No.	Rotor moment of inertia (without brake)	Weight (without brake)
n_N	h	P_N With $\Delta T=100$ K	M_0 With $\Delta T=100$ K	M_N With $\Delta T=100$ K	I_N With $\Delta T=100$ K	Order No. Core type		J	m
RPM	mm	kW	Nm	Nm	A			10^{-4} kgm ²	kg
3000	48	1.1	4	3.5	4	1FK7 044 - 7AF71- 1 7 7 7	3	1.28	7.7
	63	1.7	6.4	5.4	5.3	1FK7 061 - 7AF71- 1 7 7 7	3	3.4	10
		2.51	12	8	7.5	1FK7 064 - 7AF71- 1 7 7 7	3	6.5	15.5
	80	2.51	14	8	6.7	1FK7 082 - 7AF71- 1 7 7 7	4	14	17.2
3.14 ²⁾		22	12 ²⁾	12.5 ²⁾	1FK7 085 - 7AF71- 1 7 7 7	4	23	23.5	
4500	48	1.23	3.1	2.6	4	1FK7 043 - 7AH71- 1 7 7 7	3	1	6.7
		1.41	4	3	4.9	1FK7 044 - 7AH71- 1 7 7 7	3	1.28	7.7
	63	2.03	6.4	4.3	5.9	1FK7 061 - 7AH71- 1 7 7 7	3	3.4	10
		2.36	12	5	7	1FK7 064 - 7AH71- 1 7 7 7	3	6.5	15.5
6000	36	0.57	1.3	0.9	1.5	1FK7 033 - 7AK71- 1 7 7 7	3	0.27	3.1
	48	1.26	3.1	2	4.4	1FK7 043 - 7AK71- 1 7 7 7	3	1	6.3
•Encoder systems for motors Without DRIVE-CLiQ interface:			Incremental encoder sin/cos 1 V _{pp} 2048 pulses/rev Absolute value encoder EnDat 2048 pulses/rev ^{1) 3)} Absolute value encoder EnDat 512 pulses/rev ^{1) 4)} Single absolute value encoder EnDat 32 pulses/rev ^{1) 3)} Multi-pole resolver ⁶⁾ Resolver 2-pole			A E H G S T			
•Encoder systems for motors with DRIVE-CLiQ interface:			Incremental encoder sin/cos 1 V _{pp} 2048 pulses/rev Absolute value encoder EnDat 2048 pulses/rev ^{1) 3)} Absolute value encoder EnDat 512 pulses/rev ^{1) 4)} Single absolute value encoder EnDat 32 pulses/rev ¹⁾ Multi-pole resolver ⁶⁾ Resolver 2-pole			D F L K U P			
•Shaft end: with fitted key and keyway with fitted key and keyway Smooth shaft Smooth shaft			Tolerance: N N N N		Holding brake: without with without with		A B G H		
•Degree of protection:			IP64 IP65 and additional IP67 drive end flange IP64, anthracite paint finish IP65 and additional drive end flange IP67, anthracite paint finish IP65 and additional IP67 drive end flange, anthracite paint finish and metal rating plate on the motor			0 2 3 5 8			

Selection/Ordering data

Motor type (continued)	Stall current I_0 With M_0 $\Delta T=100$ K A	Calculated Power $P_{calc} =$ $M_0 \times n_N / 9550$ P_{calc} for M_0 $\Delta T=100$ K kW	SINAMICS motor module Rated output current		Power cable with complete shield Motor terminals (and brake terminals) via power supply connector		
			I_N With M_0 $\Delta T=100$ K A	Order No.	Power connector Size	Cable cross-section Motor ⁵⁾ mm ²	Order No. Prefabricated cable
1FK7 044 - 7AF71...	4.5	1.3	5	6SL3 120- 7 TE15 - 0AA0	1	4 x 1.5	6FX7 002- 5 7 S01 - 7 7 7 0
1FK7 061 - 7AF71...	6.1	2.0	9	- 7 TE21 - 0AA0	1	4 x 1.5	- 5 7 S01 - 7 7 7 0
1FK7 064 - 7AF71...	11	3.8	18	- 7 TE21 - 8AA0	1	4 x 1.5	- 5 7 S01 - 7 7 7 0
1FK7 082 - 7AF71...	10.6	4.4	18	- 7 TE21 - 8AA0	1	4 x 1.5	- 5 7 S01 - 7 7 7 0
1FK7 085 - 7AF71...	22.5	6.9	30	- 1TE23 - 0AA0	1.5	4 x 4	- 5 7 S41 - 7 7 7 0
1FK7 043 - 7AH71...	4.5	1.5	5	- 7 TE15 - 0AA0	1	4 x 1.5	- 5 7 S01 - 7 7 7 0
1FK7 044 - 7AH71...	6.3	1.9	9	- 7 TE21 - 0AA0	1	4 x 1.5	- 5 7 S01 - 7 7 7 0
1FK7 061 - 7AH71...	8	3.0	9	- 7 TE21 - 0AA0	1	4 x 1.5	- 5 7 S01 - 7 7 7 0
1FK7 064 - 7AH71...	15	5.7	18	- 7 TE21 - 8AA0	1	4 x 1.5	- 5 7 S01 - 7 7 7 0
1FK7 033 - 7AK71...	2.2	0.8	3	- 7 TE13 - 0AA0	1	4 x 1.5	- 5 7 S01 - 7 7 7 0
1FK7 043 - 7AK71...	6.4	1.9	9	- 7 TE21 - 0AA0	1	4 x 1.5	- 5 7 S01 - 7 7 7 0
•Single Motor Module				1			
•Double Motor Module				2			
<u>Type of power cable</u>							
•MOTION-CONNECT 800						8	
•MOTION-CONNECT 500						5	
•without brake conductors						C	
•with brake conductors						D	
Length code as well as power and signal cables, refer to Catalog, Chapter "MOTION-CONNECT connection systems".							

1) When using the absolute value encoder, M_N is reduced by 10%.

2) Rated power/current based on $n = 2500$ RPM

3) Not possible for 1FK703.

4) Only possible for 1FK703.

5) The current carrying capacity of the power cables corresponds to IEC 60204-1 for routing type C under continuous operating conditions in an ambient air temperature of +40 °C, designed/dimensioned for $I_0(100$ K), cables with PVC/PUR insulation.

6) For SINAMICS S120 a max. operating frequency of 470 Hz must be carefully maintained.

1.4 Armature short-circuit braking

The function description of armature short-circuit braking is described in the documentation "General Section for Synchronous Motors".

Dimensioning the braking resistors for optimum short-circuit braking

The correct dimensioning ensures an optimum braking time. The braking torques which are obtained are also listed in the tables. Data apply for braking from the rated speed and moment of inertia $J_{\text{external}} = J_{\text{mot}}$. If the drive is braked from another speed, then the braking time cannot be proportionally reduced. However, longer braking times cannot occur if the speed at the start of braking is less than the rated speed.

The data in the following table is calculated for rated values according to the data sheet. The variance during production as well as iron saturation have not been taken into account here. Higher currents and torques can occur than those calculated as a result of the saturation.

The ratings of the resistors must match the particular I^2t load capability, refer to the Configuration Manual "General Section for Synchronous Motors".

Table 1-2 Resistor braking for 1FK7 CT and 1FK7 HD

Motor type	Braking resistor external R_{opt} [Ω]	Average braking torque $M_{br\ rms}$ [Nm]		Max. braking torque $M_{br\ max}$ [Nm]	rms braking current $I_{br\ rms}$ [A]	
		without external braking resistor	with external braking resistor		without external braking resistor	with external braking resistor
1FK7 CT						
1FK7022-5AK71	1.0	1.8	1.9	2.3	9.0	8.7
1FK7032-5AK71	12.2	1.0	1.3	1.7	4.4	4.0
1FK7040-5AK71	18.1	0.5	1.0	1.2	3.5	3.1
1FK7042-5AF71	13.1	1.7	2.5	3.1	4.2	3.8
1FK7042-5AK71	7.2	1.2	2.7	3.3	9.0	8.1
1FK7060-5AF71	7.8	2, 2	4.5	5.5	7.9	7.1
1FK7060-5AH71	5.9	1.9	4.8	6.0	11.9	10.7
1FK7063-5AF71	4.2	4.1	9.1	11.3	15.6	14.0
1FK7063-5AH71	2.7	3.5	9.6	12.0	25.0	22.3
1FK7080-5AF71	7.8	2.9	6.9	8.6	10.1	9.0
1FK7080-5AH71	5.5	2.0	6.7	8.4	14.9	13.3
1FK7083-5AF71	3.4	5.6	14.4	17.9	22.3	19.9
1FK7083-5AH71	2.6	3.8	14.2	17.6	31.8	28.5
1FK7100-5AF71	4.1	4.2	13.4	16.6	19.9	17.8
1FK7101-5AF71	1.7	7.9	24.8	30.8	41.3	37.0
1FK7103-5AF71	1.2	10.1	33.9	42.2	59.2	53.0
1FK7105-5AC71	1.7	16.8	47.5	59.1	47.3	42.3
1FK7105-5AF71	1.1	12.9	48.3	60.0	72.5	64.9
1FK7 HD						
1FK7033-7AK71	13.4	0.6	1.1	1.4	4.1	3.7
1FK7043-7AH71	9.4	0.7	1.7	2.1	5.5	4.9
1FK7043-7AK71	7.8	0.4	1.3	1.7	6.4	5.8
1FK7044-7AF71	7.9	1.0	2.0	2.5	5.2	4.7
1FK7044-7AH71	7.0	0.8	2.0	2.4	7.0	6.3
1FK7061-7AF71	8.7	0.9	3.0	3.7	6.4	5.8
1FK7061-7AH71	6.4	0.7	3.1	3.8	9.4	8.4
1FK7064-7AF71	4.7	1.6	5.6	7.0	12.0	10.8
1FK7064-7AH71	3.8	1.2	5.7	7.1	16.7	15.0
1FK7082-7AF71	5.9	2.0	7.1	8.8	12.1	10.8
1FK7085-7AF71	2.0	2.8	11.0	13.7	26.3	23.5

1.5 Coupling output

For a description and ordering address refer to the documentation "General Section for Synchronous Motors" or Internet www.ktr.com

Table 1-3 Assignment of the coupling outputs to the motors

Shaft height of the 1 FK7 motors	d _w [mm] ¹⁾	Rotex GS Type	Torques that can be transmitted 80 or 92 Sh-A-GS pinion		TR [Nm] ⁴⁾
			T _{KN} [Nm] ²⁾	T _{Kmax} [Nm] ³⁾	
1FK7022-...	9	9	1.8	3.6	2.6
1FK7032-...	14	14	7.5	15	102
1FK704□-...	19	19/24	10	20	-
1FK706□-...	24	24/28	35	70	-
1FK708□-...	32	28/38	95	190	-
1FK710□-...	38	38/45	190	380	-

¹⁾d_w = diameter, motor shaft end

²⁾T_{KN} = rated coupling torque

³⁾T_{Kmax} = maximum coupling torque

⁴⁾T_R = friction-locked torque (torque that can be transmitted using a clamping hub at d_w)

It may be necessary to use other annular gears (e.g. Shore hardness 80 Sh-A). They must be optimally harmonized with the mounted mechanical system.



Warning

The accelerating torque may not exceed the clamping torque of the coupling!

Notice

We cannot accept any liability for the quality and properties/features of third-party products.

Electrical Connections

2.1 Connection overview

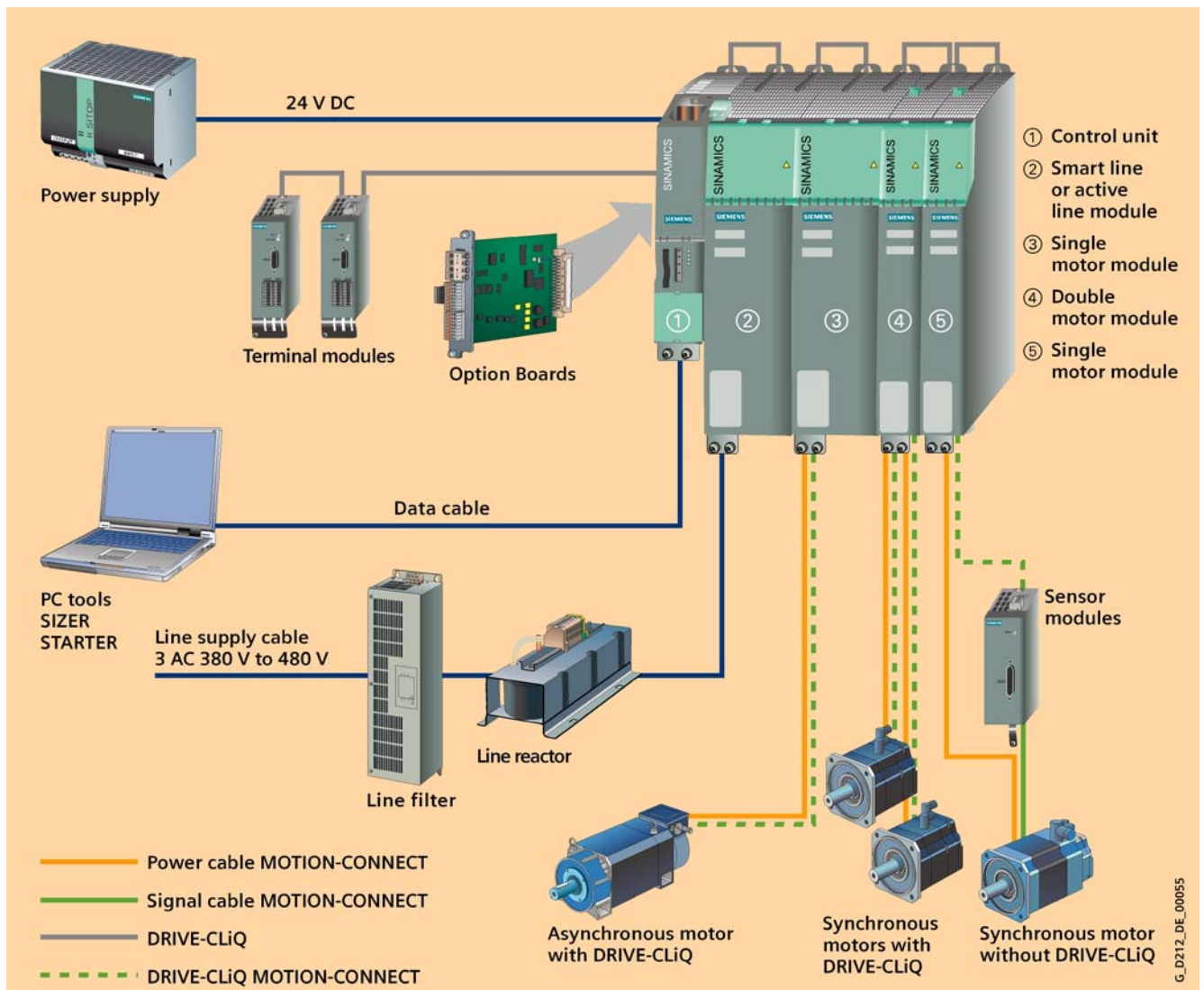

Figure 2-1 Connection overview SINAMICS S120

2.2 Power connection



Warning

The motors are not designed to be connected directly to the line supply.

Connection assignment, power connector at the motor

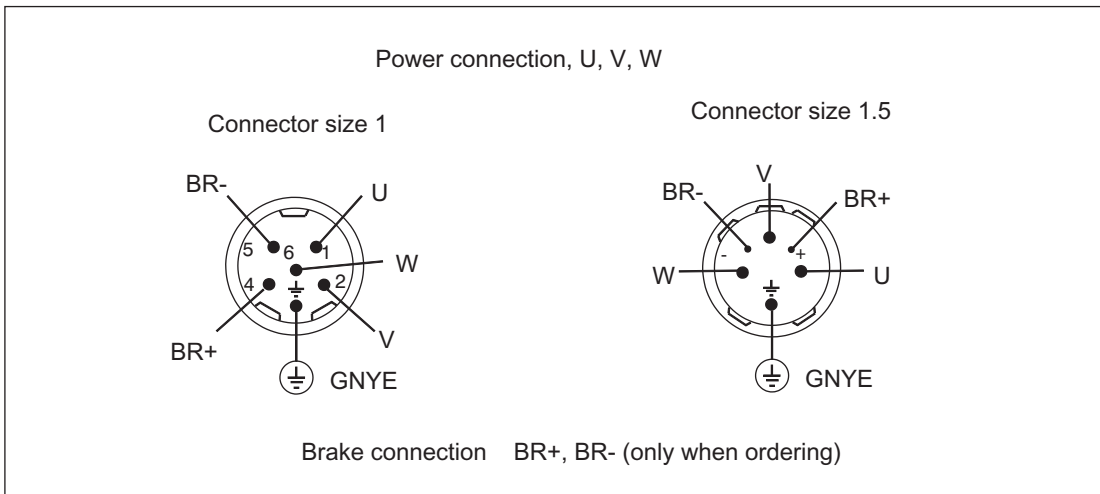

Figure 2-2 Power connection

2.3 DRIVE-CLiQ

The encoder system can only be connected to SINAMICS S120 via DRIVE-CLiQ.

The DRIVE-CLiQ interface is either established through the sensor module at the motor (motors with DRIVE-CLiQ) or in the cabinet using sensor module, cabinet-mounted (for motors without DRIVE-CLiQ).

2.4 Motors with DRIVE-CLiQ

Motors with DRIVE-CLiQ have a sensor module that includes the encoder evaluation, the motor temperature sensing as well as an electronic rating plate with a unique identification number and motor and encoder-specific data.

These motors with DRIVE-CLiQ can be connected to the corresponding motor module directly via the MOTION-CONNECT DRIVE-CLiQ cables supplied. This means that data is directly transferred to the control unit.

These motors make start-up and diagnostics much easier, as the motor and encoder type can be identified automatically.

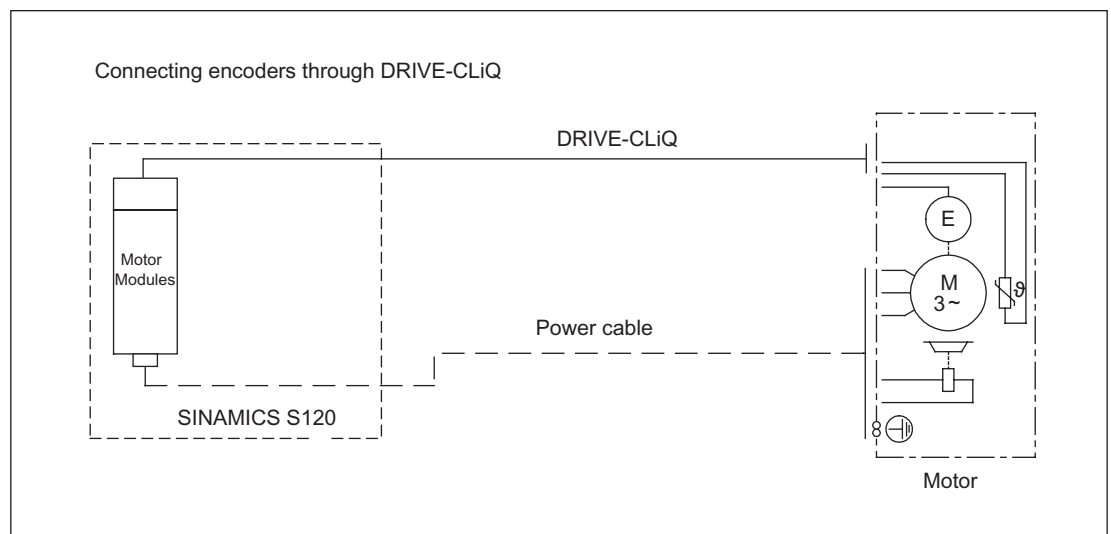

Figure 2-3 Connecting encoders for motors with DRIVE-CLiQ

2.5 Motors without DRIVE-CLiQ

When fed from SINAMICS S120, motors without DRIVE-CLiQ require a sensor module, cabinet-mounted. The sensor modules evaluate the signals from the connected motor sensors or external sensors and convert them to DRIVE-CLiQ. In conjunction with motor encoders, the motor temperature can also be evaluated using sensor modules. Additional information is provided in the SINAMICS Equipment Manual.

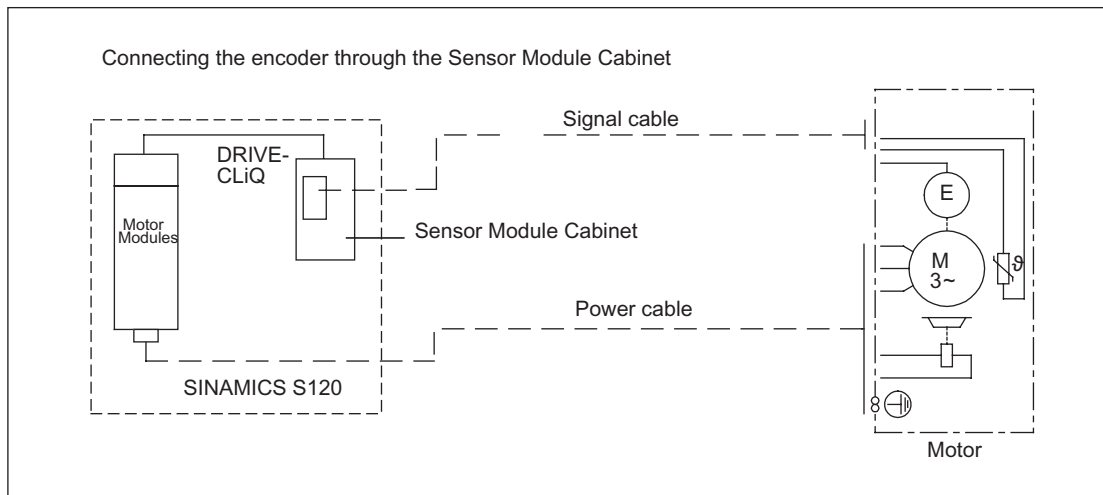

Figure 2-4 Connecting encoders without DRIVE-CLiQ

2.6 Rotating the connector at the motor

Power connector, signal connector and DRIVE-CLiQ can, to some extent, be rotated.

Notice

The permissible range of rotation may not be exceeded.

In order to guarantee the degree of protection, the connector may be rotated a max. of 10x up to its end stop.

Do not exceed the max. torque when rotating.

The connector should be rotated using a mating connector attached at the connector thread.

Connecting cables must be secured against tensile stress and bending.

The motor connectors must be secured so that they cannot be rotated any further.

It is not permissible to permanently subject connectors to forces.

Direction of rotation and torques when rotating

Table 2-1 Direction of rotation and torques when rotating the connector

	Power connector Size 1	Power connector Size 1.5	Signal connector	DRIVE-CLIQ
Direction of rotation [Degrees] clockwise	270°	270°	90°	90°
Direction of rotation [Degrees] counter- clockwise	Not possible	Not possible	90° 180° only for SH 36...80	180°
Max. torque [Nm]	8	15	8	8

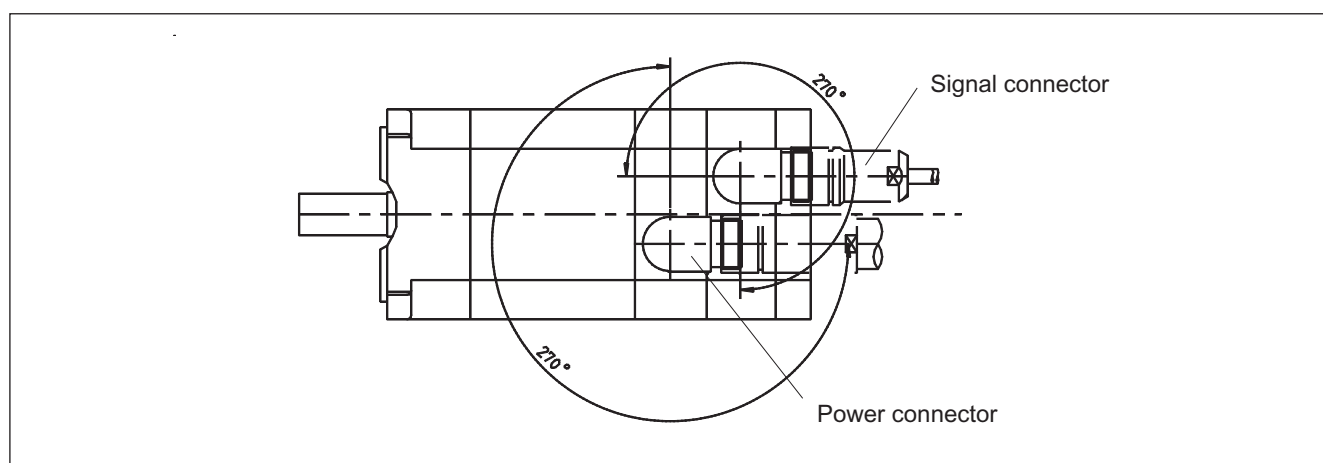

Figure 2-5 Connector that can be rotated using as an example a 1FK706 motor

Technical Data and Speed-Torque Diagrams

3.1 Introduction

Note

For converter operation on a 480 V line supply, DC link voltages occur which are greater than 600 V. The motors are suitable for DC link voltages up to 740 V.

Refer to the Documentation "General Section for Synchronous Motors" for a description of how the voltage limiting characteristics are shifted.

The specified thermal S3 limiting characteristics are referred to $\Delta T = 100$ K for

- 1 min cycle duration for SH 28 and 36
 - 10 min cycle duration for SH 48, 63, 80, 100, 132, 160
-

3.2 Speed-torque diagrams 1FK7 CT

Table 3-1 1FK7022 CT

Technical data	Code	Units	-5AK71	
Engineering data				
Rated speed	n_N	RPM	6000	
Pole number	2p		6	
Rated torque (100 K)	$M_{N(100 K)}$	Nm	0.6	
Rated current	I_N	A	1.4	
Stall torque (60K)	$M_0(60 K)$	Nm	0.7	
Stall torque (100K)	$M_0(100 K)$	Nm	0.85	
Stall current (60K)	$I_{0(60 K)}$	A	1.5	
Stall current (100K)	$I_{0(100 K)}$	A	1.8	
Moment of inertia (with brake)	J_{mot}	10^{-4} kgm ²	0.35	
Moment of inertia (without brake)	J_{mot}	10^{-4} kgm ²	0.28	
Optimum operating point				
Optimum speed	n_{opt}	RPM	6000	
Optimum power	P_{opt}	kW	0.38	
Limiting data				
Max. perm. speed (mechan.)	n_{max}	RPM	10000	
Max. torque	M_{max}	Nm	3.4	
Peak current	I_{max}	A	7.5	
Physical constants				
Torque constant	k_T	Nm/A	0.46	
Voltage constant	k_E	V/1000 RPM	29	
Winding resistance at 20°C	R_{ph}	Ohm	4.2	
Rotating field inductance	L_D	mH	5.5	
Electrical time constant	T_{el}	ms	1.3	
Shaft torsional stiffness	C_t	Nm/rad	3000	
Mechanical time constant	T_{mech}	ms	1.7	
Thermal time constant	T_{th}	min	18	
Weight with brake	m	kg	2.0	
Weight without brake	m	kg	1.8	

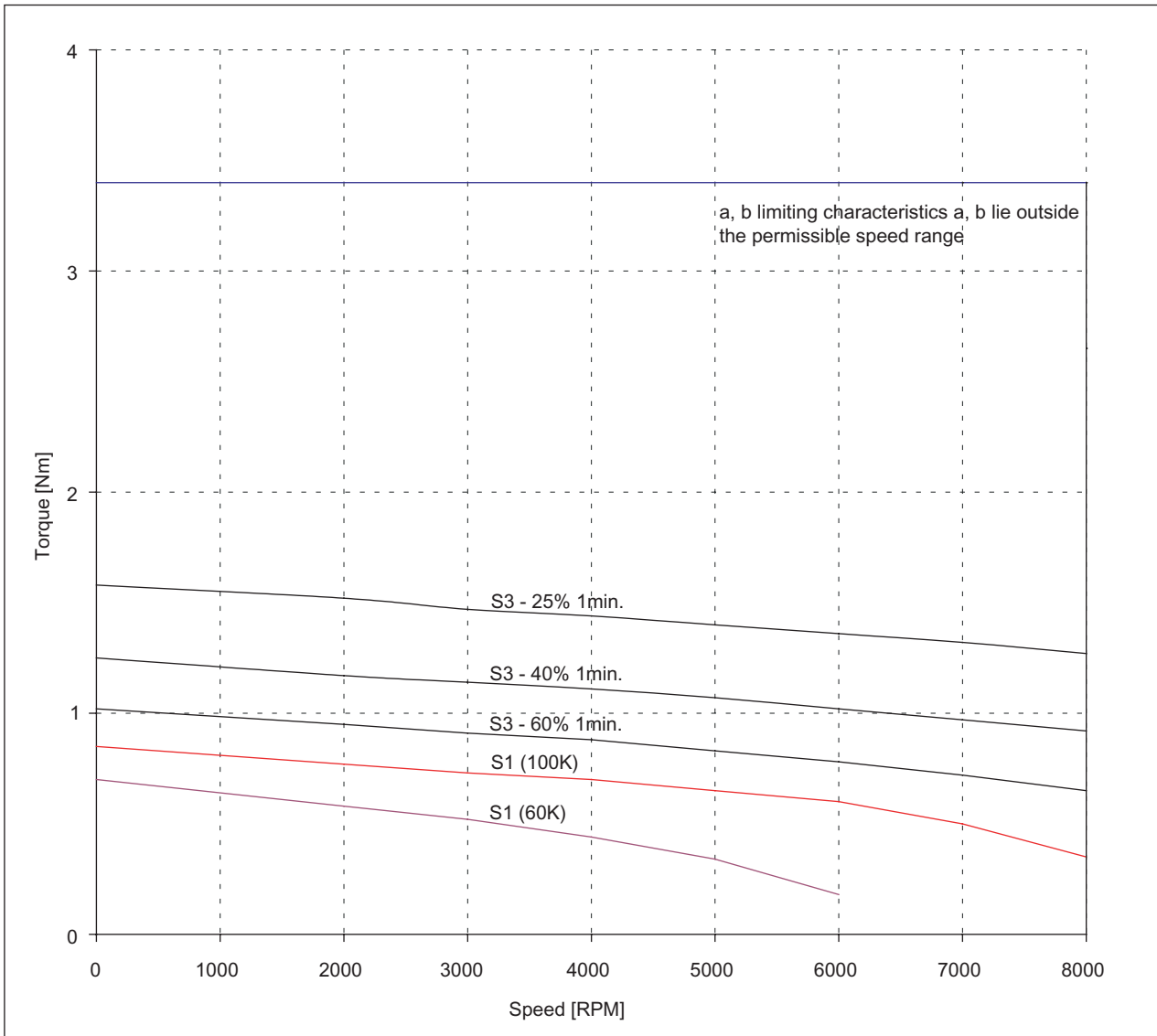

Figure 3-1 Speed-torque diagram 1FK7022-5AK71 CT

[a] SINAMICS S120 SMART LINE $V_{DC \text{ link}}=540V$ (DC), $V_{mot}=380V_{rms}$
 [b] SINAMICS S120 ACTIVE LINE $V_{DC \text{ link}}=600V$ (DC), $V_{mot}=425V_{rms}$

3.2 Speed-torque diagrams 1FK7 CT

Table 3-2 1FK7032 CT

Technical data	Code	Units	-5AK71	
Engineering data				
Rated speed	n_N	RPM	6000	
Pole number	$2p$		6	
Rated torque (100 K)	$M_{N(100 K)}$	Nm	0.8	
Rated current	I_N	A	1.4	
Stall torque (60K)	$M_{0(60 K)}$	Nm	0.85	
Stall torque (100K)	$M_{0(100 K)}$	Nm	1.1	
Stall current (60K)	$I_{0(60 K)}$	A	1.4	
Stall current (100K)	$I_{0(100 K)}$	A	1.7	
Moment of inertia (with brake)	J_{mot}	10^{-4} kgm ²	0.69	
Moment of inertia (without brake)	J_{mot}	10^{-4} kgm ²	0.61	
Optimum operating point				
Optimum speed	n_{opt}	RPM	6000	
Optimum power	P_{opt}	kW	0.5	
Limiting data				
Max. perm. speed (mechan.)	n_{max}	RPM	10000	
Max. torque	M_{max}	Nm	4.5	
Peak current	I_{max}	A	7.5	
Physical constants				
Torque constant	k_T	Nm/A	0.66	
Voltage constant	k_E	V/1000 RPM	42	
Winding resistance at 20°C	R_{ph}	Ohm	5.2	
Rotating field inductance	L_D	mH	18.5	
Electrical time constant	T_{el}	ms	3.6	
Shaft torsional stiffness	C_t	Nm/rad	6500	
Mechanical time constant	T_{mech}	ms	2.2	
Thermal time constant	T_{th}	min	25	
Weight with brake	m	kg	3.0	
Weight without brake	m	kg	2.7	

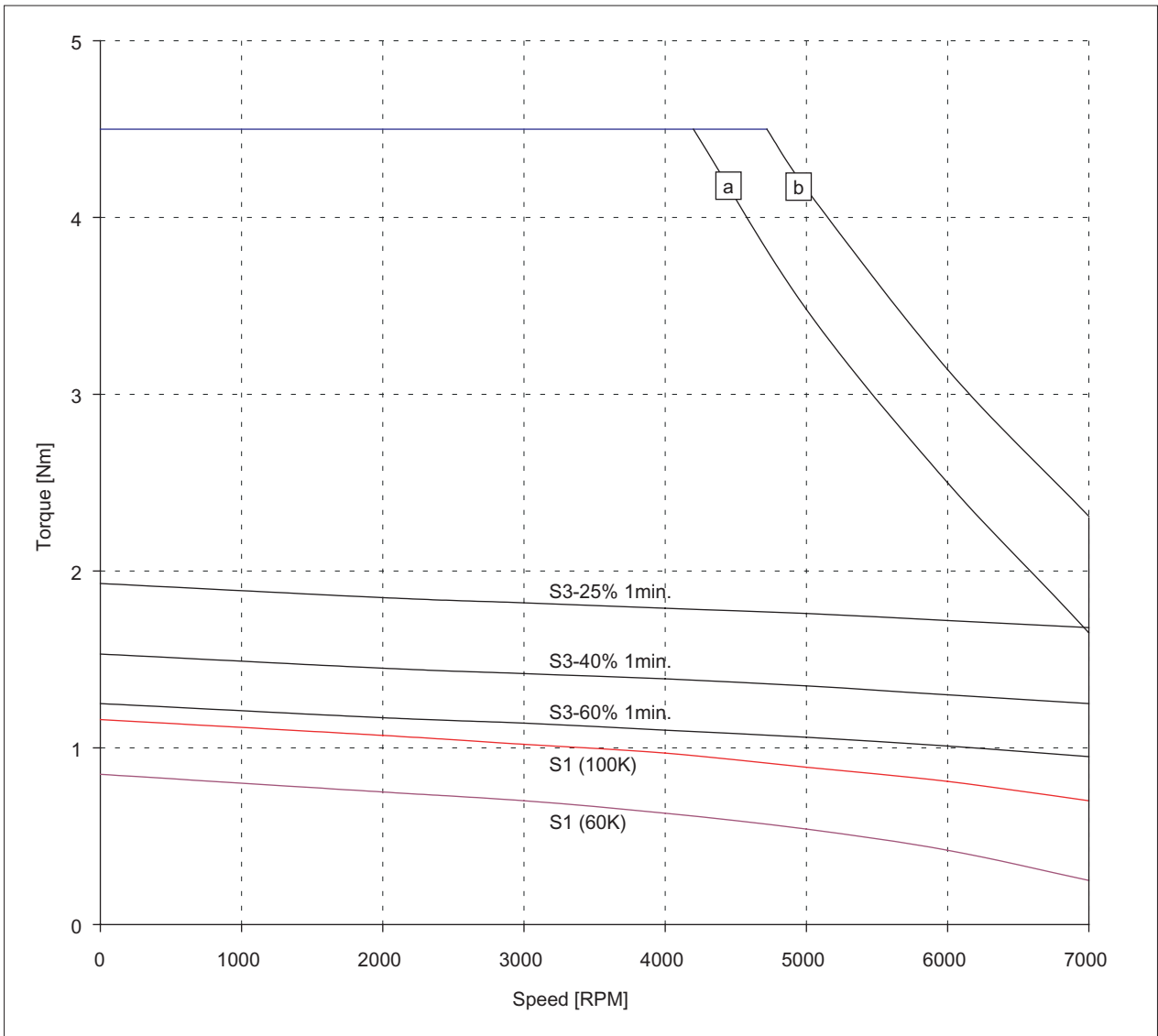

Figure 3-2 Speed-torque diagram 1FK7032-5AK71 CT

[a] SINAMICS S120 SMART LINE $V_{DC\ link}=540V$ (DC), $V_{mot}=380V$ rms
 [b] SINAMICS S120 ACTIVE LINE $V_{DC\ link}=600V$ (DC), $V_{mot}=425V$ rms

3.2 Speed-torque diagrams 1FK7 CT

Table 3-3 1FK7040 CT

Technical data	Code	Units	-5AK71	
Engineering data				
Rated speed	n_N	RPM	6000	
Pole number	$2p$		8	
Rated torque (100 K)	$M_{N(100 K)}$	Nm	1.1	
Rated current	I_N	A	1.7	
Stall torque (60K)	$M_{0(60 K)}$	Nm	1.3	
Stall torque (100K)	$M_{0(100 K)}$	Nm	1.6	
Stall current (60K)	$I_{0(60 K)}$	A	1.8	
Stall current (100K)	$I_{0(100 K)}$	A	2.25	
Moment of inertia (with brake)	J_{mot}	10^{-4} kgm ²	2.41	
Moment of inertia (without brake)	J_{mot}	10^{-4} kgm ²	1.69	
Optimum operating point				
Optimum speed	n_{opt}	RPM	6000	
Optimum power	P_{opt}	kW	0.69	
Limiting data				
Max. perm. speed (mechan.)	n_{max}	RPM	9000	
Max. torque	M_{max}	Nm	5.1	
Peak current	I_{max}	A	7.7	
Physical constants				
Torque constant	k_T	Nm/A	0.68	
Voltage constant	k_E	V/1000 RPM	43	
Winding resistance at 20°C	R_{ph}	Ohm	3.3	
Rotating field inductance	L_D	mH	17	
Electrical time constant	T_{el}	ms	5.15	
Shaft torsional stiffness	C_t	Nm/rad	19000	
Mechanical time constant	T_{mech}	ms	3.62	
Thermal time constant	T_{th}	min	25	
Weight with brake	m	kg	4.0	
Weight without brake	m	kg	3.5	

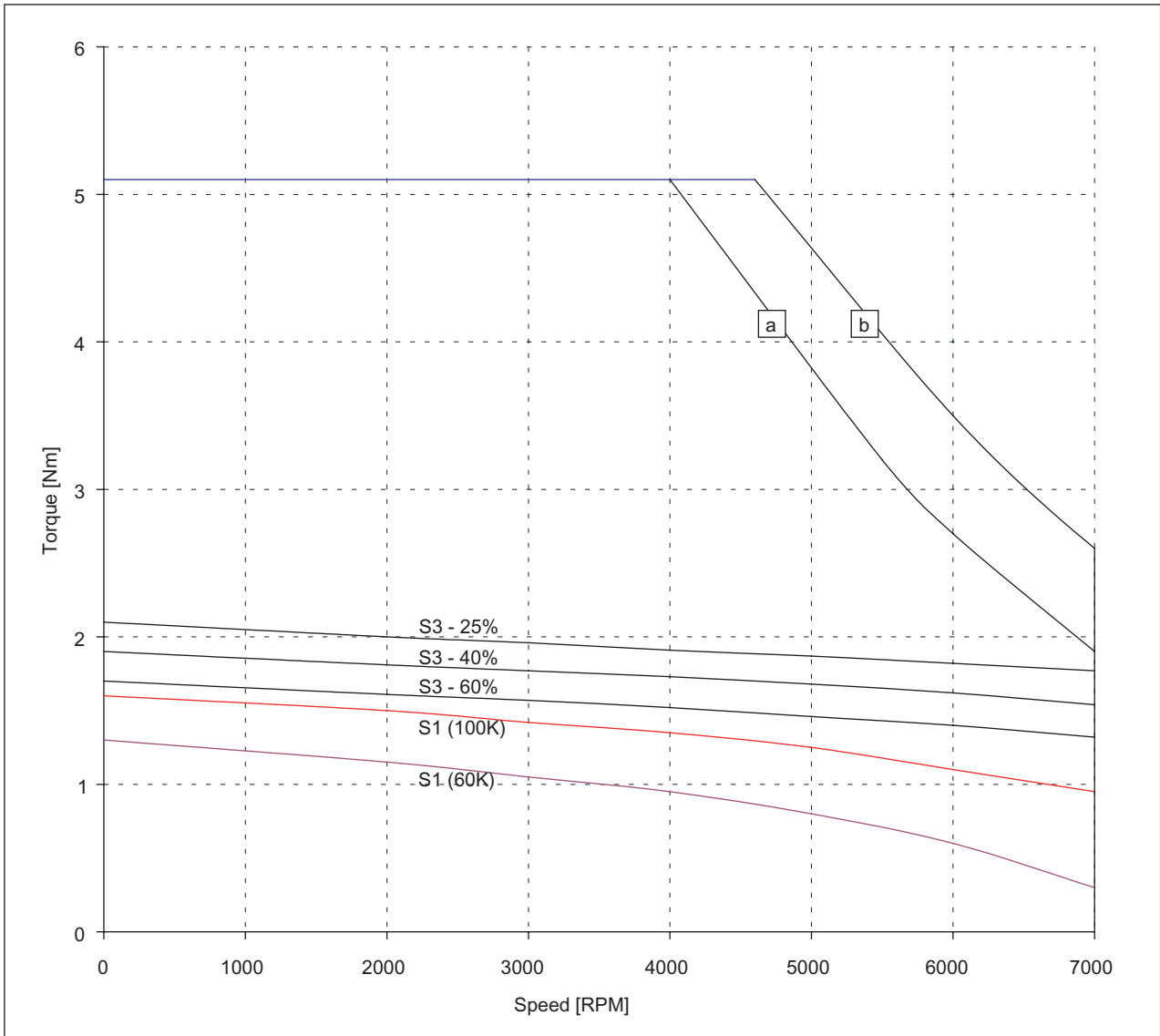

Figure 3-3 Speed-torque diagram 1FK7040-5AK71 CT

- [a] SINAMICS S120 SMART LINE $V_{DC \text{ link}}=540V$ (DC), $V_{mot}=380V$ rms
- [b] SINAMICS S120 ACTIVE LINE $V_{DC \text{ link}}=600V$ (DC), $V_{mot}=425V$ rms

3.2 Speed-torque diagrams 1FK7 CT

Table 3-4 1FK7042 CT

Technical data	Code	Units	-5AF71	-5AK71
Engineering data				
Rated speed	n_N	RPM	3000	6000
Pole number	$2p$		8	8
Rated torque (100 K)	$M_{N(100 K)}$	Nm	2.6	1.5
Rated current	I_N	A	1.95	2.45
Stall torque (60K)	$M_{0(60 K)}$	Nm	2.5	2.5
Stall torque (100K)	$M_{0(100 K)}$	Nm	3.0	3.0
Stall current (60K)	$I_{0(60 K)}$	A	1.8	3.6
Stall current (100K)	$I_{0(100 K)}$	A	2.2	4.4
Moment of inertia (with brake)	J_{mot}	10^{-4} kgm ²	3.73	3.73
Moment of inertia (without brake)	J_{mot}	10^{-4} kgm ²	3.01	3.01
Optimum operating point				
Optimum speed	n_{opt}	RPM	3000	5000
Optimum power	P_{opt}	kW	0.82	1.02
Limiting data				
Max. perm. speed (mechan.)	n_{max}	RPM	9000	9000
Max. torque	M_{max}	Nm	10.5	10.5
Peak current	I_{max}	A	7.35	15.3
Physical constants				
Torque constant	k_T	Nm/A	1.4	0.69
Voltage constant	k_E	V/1000 RPM	89	44
Winding resistance at 20°C	R_{ph}	Ohm	5.15	1.2
Rotating field inductance	L_D	mH	29	6.7
Electrical time constant	T_{el}	ms	5.6	5.6
Shaft torsional stiffness	C_t	Nm/rad	16000	16000
Mechanical time constant	T_{mech}	ms	2.37	2.27
Thermal time constant	T_{th}	min	30	30
Weight with brake	m	kg	5.4	5.4
Weight without brake	m	kg	4.9	4.9

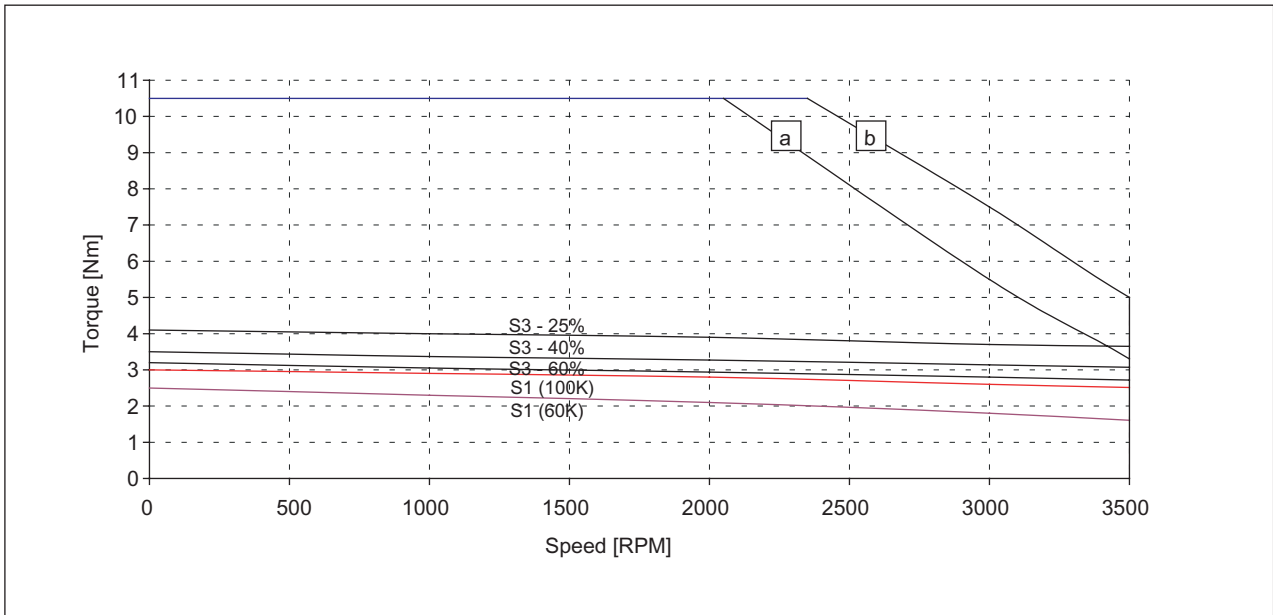

Figure 3-4 Speed-torque diagram 1FK7042-5AF71 CT

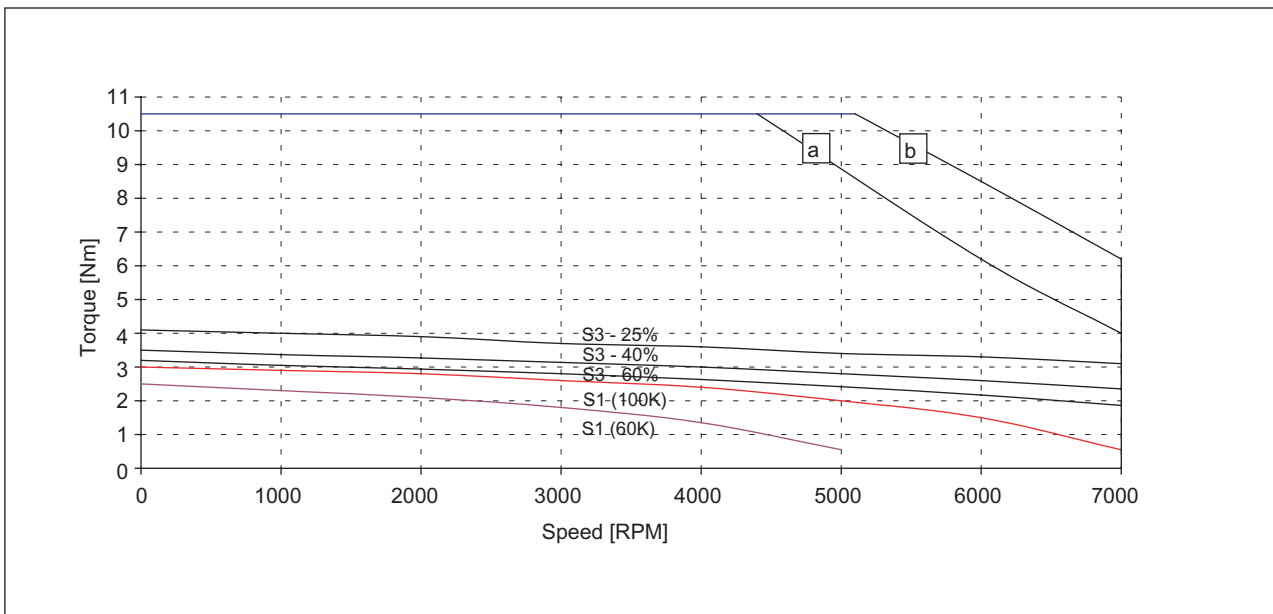

Figure 3-5 Speed-torque diagram 1FK7042-5AK71 CT

[a] SINAMICS S120 SMART LINE $V_{DC \text{ link}}=540V$ (DC), $V_{mot}=380V$ rms
 [b] SINAMICS S120 ACTIVE LINE $V_{DC \text{ link}}=600V$ (DC), $V_{mot}=425V$ rms

3.2 Speed-torque diagrams 1FK7 CT

Table 3-5 1FK7060 CT

Technical data	Code	Units	-5AF71	-5AH71
Engineering data				
Rated speed	n_N	RPM	3000	4500
Pole number	$2p$		8	8
Rated torque (100 K)	$M_{N(100\text{ K})}$	Nm	4.7	3.7
Rated current	I_N	A	3.7	4.1
Stall torque (60K)	$M_{0(60\text{ K})}$	Nm	5.0	5.0
Stall torque (100K)	$M_{0(100\text{ K})}$	Nm	6.0	6.0
Stall current (60K)	$I_{0(60\text{ K})}$	A	3.7	5.1
Stall current (100K)	$I_{0(100\text{ K})}$	A	4.5	6.2
Moment of inertia (with brake)	J_{mot}	10^{-4} kgm ²	10.2	10.2
Moment of inertia (without brake)	J_{mot}	10^{-4} kgm ²	7.95	7.95
Optimum operating point				
Optimum speed	n_{opt}	RPM	3000	4500
Optimum power	P_{opt}	kW	1.48	1.74
Limiting data				
Max. perm. speed (mechan.)	n_{max}	RPM	7200	7200
Max. torque	M_{max}	Nm	18	18
Peak current	I_{max}	A	15	19.5
Physical constants				
Torque constant	k_T	Nm/A	1.33	0.95
Voltage constant	k_E	V/1000 RPM	84.5	60.5
Winding resistance at 20°C	R_{ph}	Ohm	1.44	0.73
Rotating field inductance	L_D	mH	14.7	7.0
Electrical time constant	T_{el}	ms	10.2	9.6
Shaft torsional stiffness	C_t	Nm/rad	42000	42000
Mechanical time constant	T_{mech}	ms	1.94	1.93
Thermal time constant	T_{th}	min	30	30
Weight with brake	m	kg	8	8
Weight without brake	m	kg	7	7

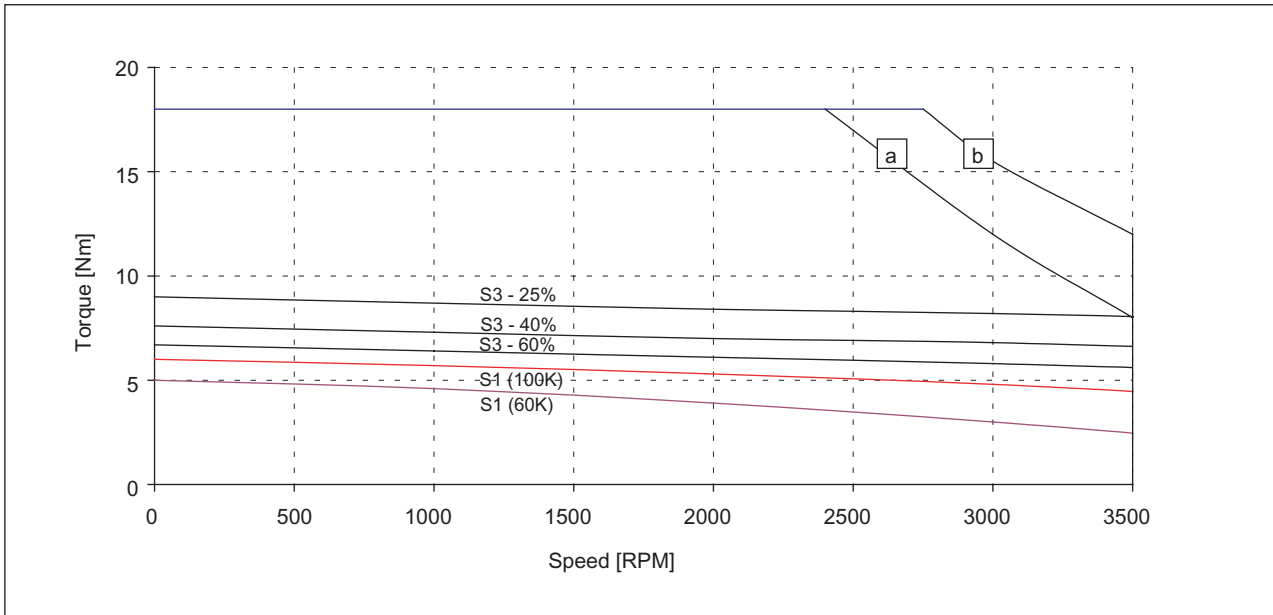

Figure 3-6 Speed-torque diagram 1FK7060-5AF71 CT

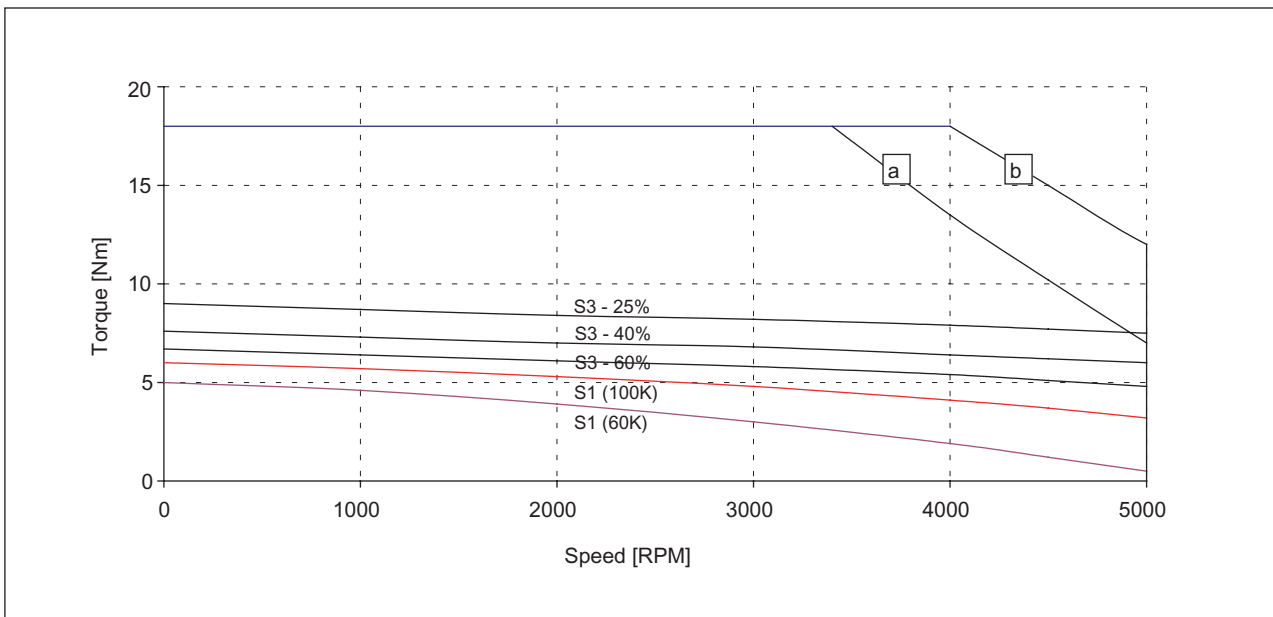

Figure 3-7 Speed-torque diagram 1FK7060-5AH71 CT

[a] SINAMICS S120 SMART LINE $V_{DC \text{ link}}=540V$ (DC), $V_{mot}=380V$ rms
 [b] SINAMICS S120 ACTIVE LINE $V_{DC \text{ link}}=600V$ (DC), $V_{mot}=425V$ rms

3.2 Speed-torque diagrams 1FK7 CT

Table 3-6 1FK7063 CT

Technical data	Code	Units	-5AF71	-5AH71
Engineering data				
Rated speed	n_N	RPM	3000	4500
Pole number	$2p$		8	8
Rated torque (100 K)	$M_{N(100\text{ K})}$	Nm	7.3	3
Rated current	I_N	A	5.6	3.8
Stall torque (60K)	$M_{0(60\text{ K})}$	Nm	9.1	9.1
Stall torque (100K)	$M_{0(100\text{ K})}$	Nm	11	11
Stall current (60K)	$I_{0(60\text{ K})}$	A	6.6	9.9
Stall current (100K)	$I_{0(100\text{ K})}$	A	8.0	12.0
Moment of inertia (with brake)	J_{mot}	10^{-4} kgm ²	17.3	17.3
Moment of inertia (without brake)	J_{mot}	10^{-4} kgm ²	15.1	15.1
Optimum operating point				
Optimum speed	n_{opt}	RPM	3000	3300
Optimum power	P_{opt}	kW	2.29	2.32
Limiting data				
Max. perm. speed (mechan.)	n_{max}	RPM	7200	7200
Max. torque	M_{max}	Nm	35	35
Peak current	I_{max}	A	28	42
Physical constants				
Torque constant	k_T	Nm/A	1.37	0.91
Voltage constant	k_E	V/1000 RPM	87.5	58
Winding resistance at 20°C	R_{ph}	Ohm	0.65	0.29
Rotating field inductance	L_D	mH	7.7	3.2
Electrical time constant	T_{el}	ms	11.8	11
Shaft torsional stiffness	C_t	Nm/rad	35000	35000
Mechanical time constant	T_{mech}	ms	1.56	1.58
Thermal time constant	T_{th}	min	40	40
Weight with brake	m	kg	12	12
Weight without brake	m	kg	11.5	11.5

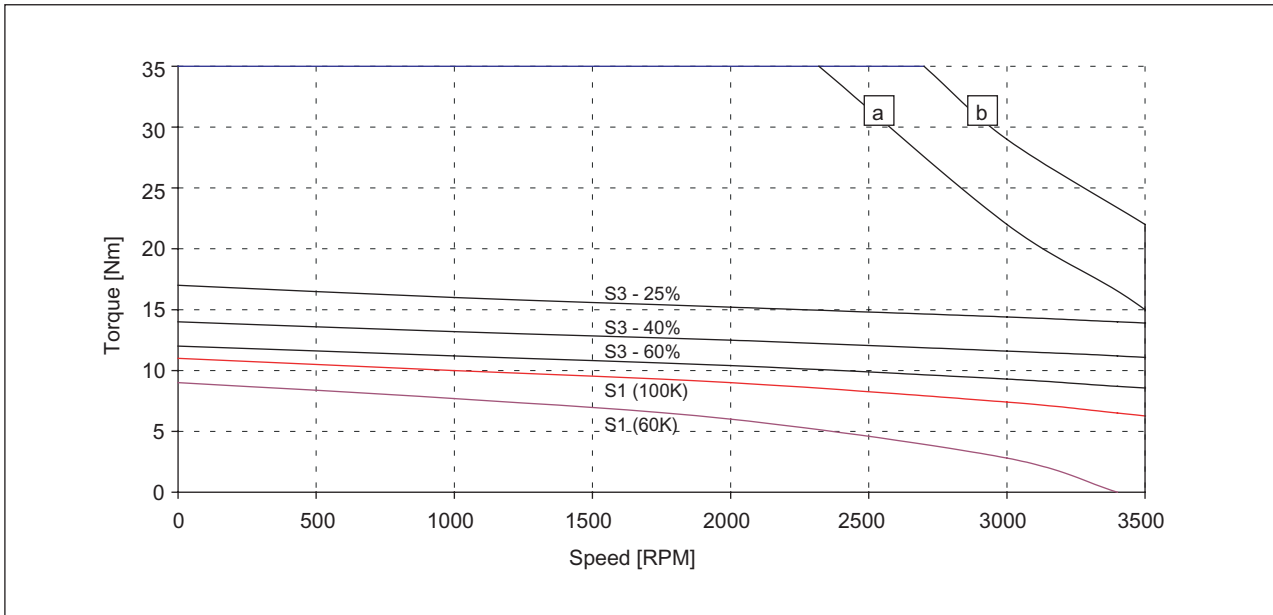

Figure 3-8 Speed-torque diagram 1FK7063-5AF71 CT

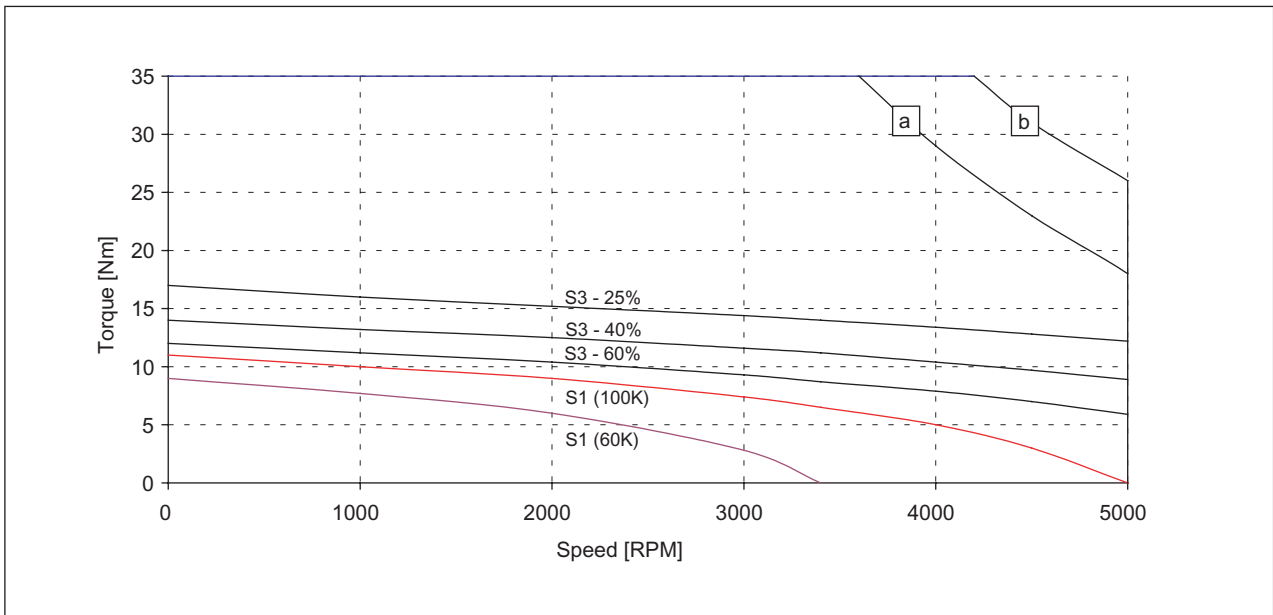

Figure 3-9 Speed-torque diagram 1FK7063-5AH71 CT

[a] SINAMICS S120 SMART LINE $V_{DC \text{ link}}=540V$ (DC), $V_{mot}=380V$ rms
 [b] SINAMICS S120 ACTIVE LINE $V_{DC \text{ link}}=600V$ (DC), $V_{mot}=425V$ rms

3.2 Speed-torque diagrams 1FK7 CT

Table 3-7 1FK7080 CT

Technical data	Code	Units	-5AF71	-5AH71
Engineering data				
Rated speed	n_N	RPM	3000	4500
Pole number	$2p$		8	8
Rated torque (100 K)	$M_{N(100 K)}$	Nm	6.8	4.5
Rated current	I_N	A	4.4	4.7
Stall torque (60K)	$M_{0(60 K)}$	Nm	6.6	6.6
Stall torque (100K)	$M_{0(100 K)}$	Nm	8	8
Stall current (60K)	$I_{0(60 K)}$	A	4	6.1
Stall current (100K)	$I_{0(100 K)}$	A	4.8	7.4
Moment of inertia (with brake)	J_{mot}	10^{-4} kgm ²	18.1	18.1
Moment of inertia (without brake)	J_{mot}	10^{-4} kgm ²	15	15
Optimum operating point				
Optimum speed	n_{opt}	RPM	3000	4000
Optimum power	P_{opt}	kW	2.14	2.39
Limiting data				
Max. perm. speed (mechan.)	n_{max}	RPM	6000	6000
Max. torque	M_{max}	Nm	25	25
Peak current	I_{max}	A	18	25
Physical constants				
Torque constant	k_T	Nm/A	1.61	1.06
Voltage constant	k_E	V/1000 RPM	102.5	68.0
Winding resistance at 20°C	R_{ph}	Ohm	1.04	0.44
Rotating field inductance	L_D	mH	14.0	6.3
Electrical time constant	T_{el}	ms	13.5	14.3
Shaft torsional stiffness	C_t	Nm/rad	126000	126000
Mechanical time constant	T_{mech}	ms	1.78	1.76
Thermal time constant	T_{th}	min	40	40
Weight with brake	m	kg	12.5	12.5
Weight without brake	m	kg	10	10

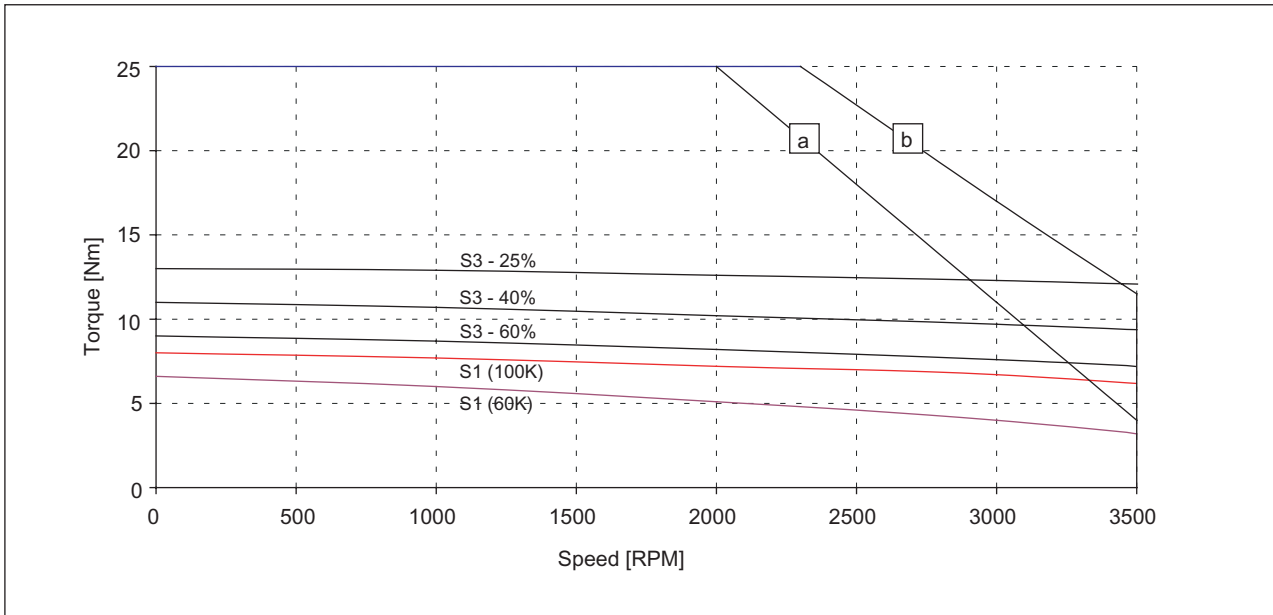

Figure 3-10 Speed-torque diagram 1FK7080-5AF71 CT

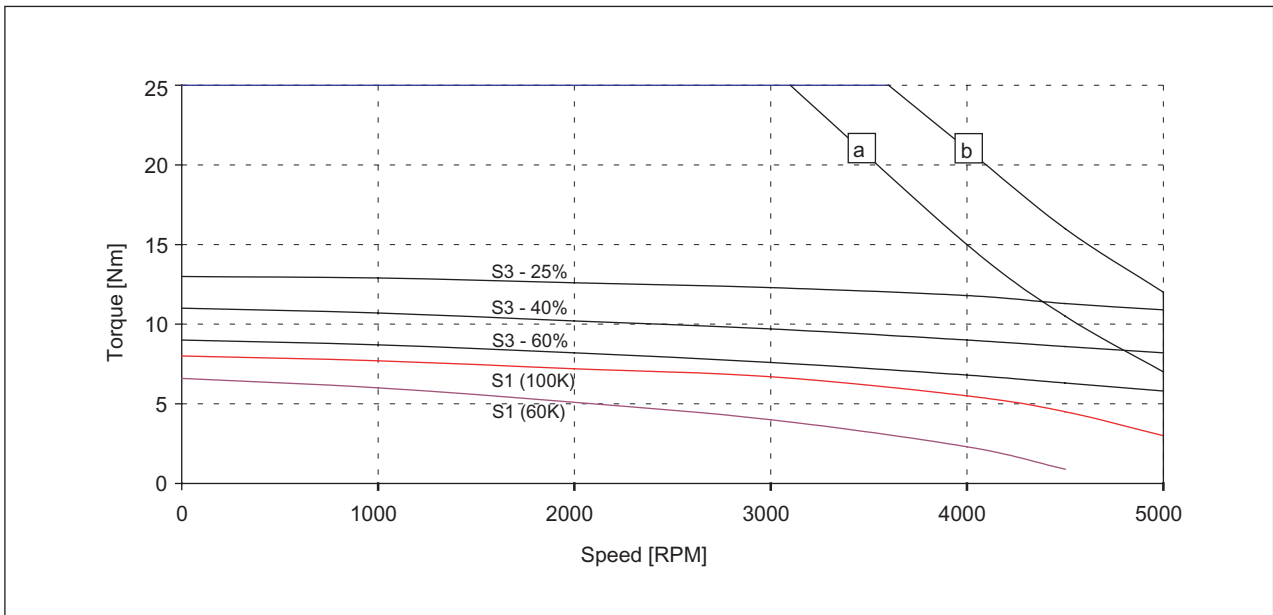

Figure 3-11 Speed-torque diagram 1FK7080-5AH71 CT

[a] SINAMICS S120 SMART LINE $V_{DC\ link}=540V$ (DC), $V_{mot}=380V$ rms
 [b] SINAMICS S120 ACTIVE LINE $V_{DC\ link}=600V$ (DC), $V_{mot}=425V$ rms

3.2 Speed-torque diagrams 1FK7 CT

Table 3-8 1FK7083 CT

Technical data	Code	Units	-5AF71	-5AH71
Engineering data				
Rated speed	n_N	RPM	3000	4500
Pole number	$2p$		8	8
Rated torque (100 K)	$M_{N(100\text{ K})}$	Nm	10.5	3
Rated current	I_N	A	7.4	3.6
Stall torque (60K)	$M_{0(60\text{ K})}$	Nm	13.3	13.3
Stall torque (100K)	$M_{0(100\text{ K})}$	Nm	16	16
Stall current (60K)	$I_{0(60\text{ K})}$	A	8.6	12.4
Stall current (100K)	$I_{0(100\text{ K})}$	A	10.4	15
Moment of inertia (with brake)	J_{mot}	10^{-4} kgm ²	35.9	35.9
Moment of inertia (without brake)	J_{mot}	10^{-4} kgm ²	27.3	27.3
Optimum operating point				
Optimum speed	n_{opt}	RPM	3000	3000
Optimum power	P_{opt}	kW	3.3	3.3
Limiting data				
Max. perm. speed (mechan.)	n_{max}	RPM	6000	6000
Max. torque	M_{max}	Nm	50	50
Peak current	I_{max}	A	37	52
Physical constants				
Torque constant	k_T	Nm/A	1.52	1.05
Voltage constant	k_E	V/1000 RPM	97	67
Winding resistance at 20°C	R_{ph}	Ohm	0.4	0.17
Rotating field inductance	L_D	mH	6.0	2.9
Electrical time constant	T_{el}	ms	15	17
Shaft torsional stiffness	C_t	Nm/rad	105000	105000
Mechanical time constant	T_{mech}	ms	1.41	1.26
Thermal time constant	T_{th}	min	50	50
Weight with brake	m	kg	16.5	16.5
Weight without brake	m	kg	14	14

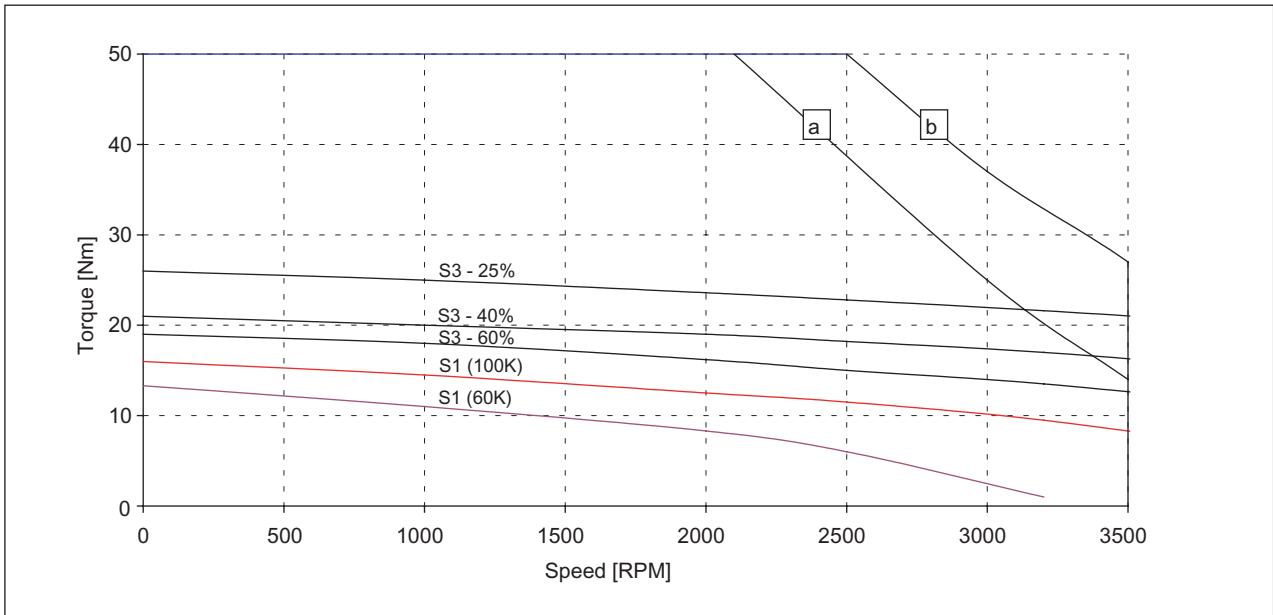

Figure 3-12 Speed-torque diagram 1FK7083-5AF71

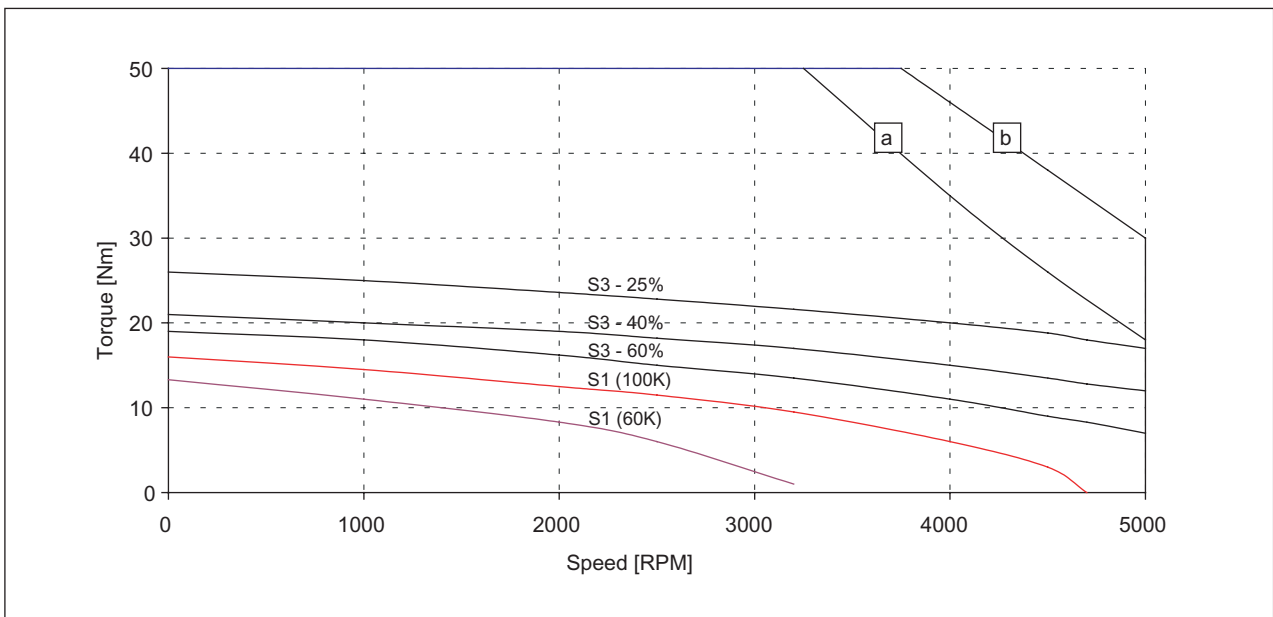

Figure 3-13 Speed-torque diagram 1FK7083-5AH71 CT

[a] SINAMICS S120 SMART LINE $V_{DC\ link}=540V$ (DC), $V_{mot}=380V$ rms
 [b] SINAMICS S120 ACTIVE LINE $V_{DC\ link}=600V$ (DC), $V_{mot}=425V$ rms

3.2 Speed-torque diagrams 1FK7 CT

Table 3-9 1FK7100 CT

Technical data	Code	Units	-5AF71	
Engineering data				
Rated speed	n_N	RPM	3000	
Pole number	2p		8	
Rated torque (100 K)	$M_{N(100 K)}$	Nm	12	
Rated current	I_N	A	8	
Stall torque (60K)	$M_{0(60 K)}$	Nm	15	
Stall torque (100K)	$M_{0(100 K)}$	Nm	18	
Stall current (60K)	$I_{0(60 K)}$	A	9.2	
Stall current (100K)	$I_{0(100 K)}$	A	11.2	
Moment of inertia (with brake)	J_{mot}	10^{-4} kgm ²	63.9	
Moment of inertia (without brake)	J_{mot}	10^{-4} kgm ²	55.3	
Optimum operating point				
Optimum speed	n_{opt}	RPM	3000	
Optimum power	P_{opt}	kW	3.77	
Limiting data				
Max. perm. speed (mechan.)	n_{max}	RPM	5000	
Max. torque	M_{max}	Nm	55	
Peak current	I_{max}	A	37	
Physical constants				
Torque constant	k_T	Nm/A	1.59	
Voltage constant	k_E	V/1000 RPM	101	
Winding resistance at 20°C	R_{ph}	Ohm	0.34	
Rotating field inductance	L_D	mH	7.0	
Electrical time constant	T_{el}	ms	20.5	
Shaft torsional stiffness	C_t	Nm/rad	184000	
Mechanical time constant	T_{mech}	ms	2.23	
Thermal time constant	T_{th}	min	55	
Weight with brake	m	kg	21.5	
Weight without brake	m	kg	19	

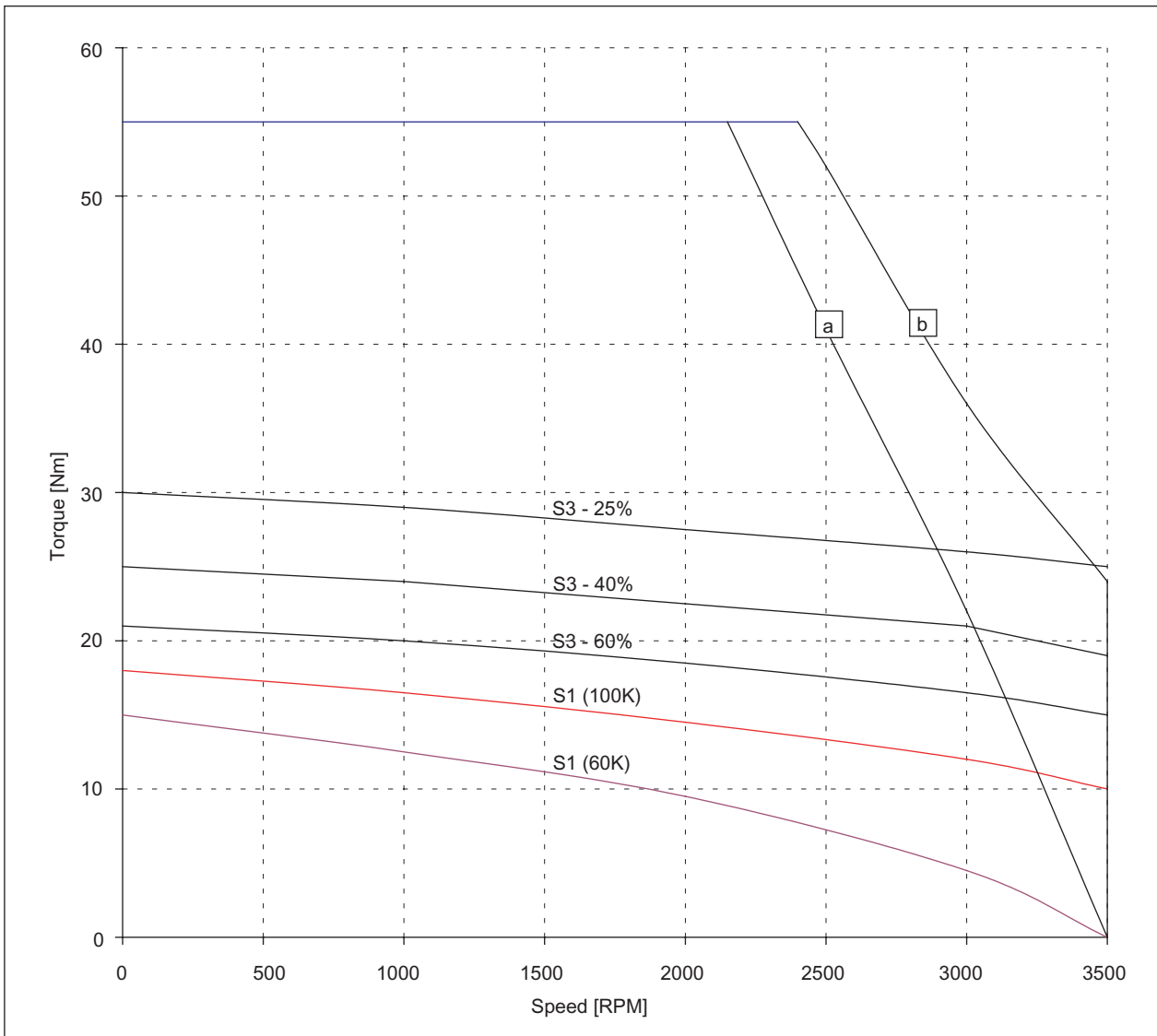

Figure 3-14 Speed-torque diagram 1FK7100-5AF71 CT

[a] SINAMICS S120 SMART LINE $V_{DC\ link}=540V$ (DC), $V_{mot}=380V$ rms
 [b] SINAMICS S120 ACTIVE LINE $V_{DC\ link}=600V$ (DC), $V_{mot}=425V$ rms

3.2 Speed-torque diagrams 1FK7 CT

Table 3-10 1FK7101 CT

Technical data	Code	Units	-5AF71	
Engineering data				
Rated speed	n_N	RPM	3000	
Pole number	$2p$		8	
Rated torque (100 K)	$M_{N(100 K)}$	Nm	15.5	
Rated current	I_N	A	11.8	
Stall torque (60K)	$M_{0(60 K)}$	Nm	22.4	
Stall torque (100K)	$M_{0(100 K)}$	Nm	27	
Stall current (60K)	$I_{0(60 K)}$	A	15.7	
Stall current (100K)	$I_{0(100 K)}$	A	19	
Moment of inertia (with brake)	J_{mot}	10^{-4} kgm ²	92.3	
Moment of inertia (without brake)	J_{mot}	10^{-4} kgm ²	79.9	
Optimum operating point				
Optimum speed	n_{opt}	RPM	3000	
Optimum power	P_{opt}	kW	4.87	
Limiting data				
Max. perm. speed (mechan.)	n_{max}	RPM	5000	
Max. torque	M_{max}	Nm	80	
Peak current	I_{max}	A	63	
Physical constants				
Torque constant	k_T	Nm/A	1.41	
Voltage constant	k_E	V/1000 RPM	90	
Winding resistance at 20°C	R_{ph}	Ohm	0.15	
Rotating field inductance	L_D	mH	3.0	
Electrical time constant	T_{el}	ms	20	
Shaft torsional stiffness	C_t	Nm/rad	165000	
Mechanical time constant	T_{mech}	ms	1.80	
Thermal time constant	T_{th}	min	60	
Weight with brake	m	kg	24	
Weight without brake	m	kg	21	

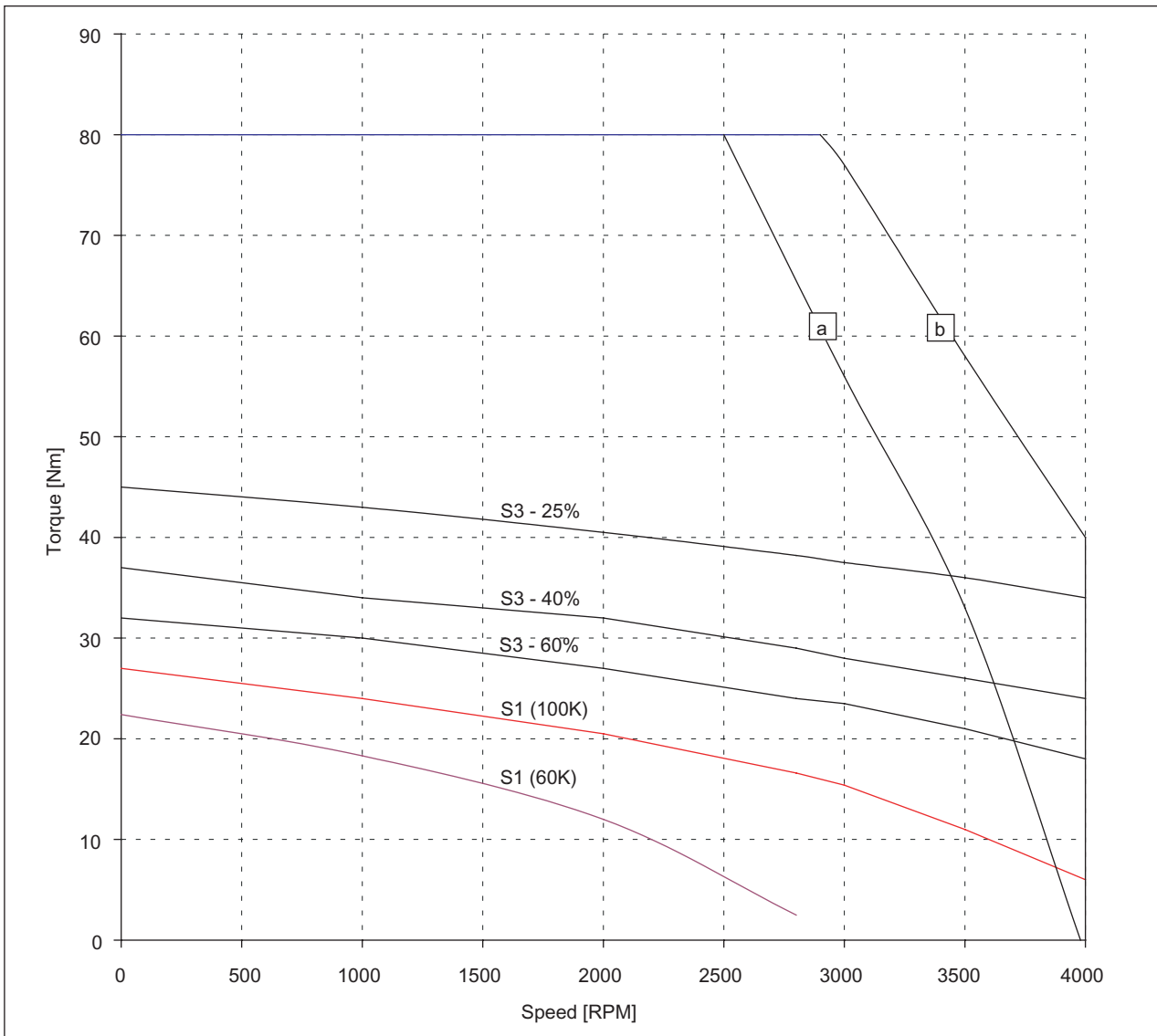

Figure 3-15 Speed-torque diagram 1FK7101-5AF71 CT

[a] SINAMICS S120 SMART LINE $V_{DC\ link}=540V$ (DC), $V_{mot}=380V$ rms
 [b] SINAMICS S120 ACTIVE LINE $V_{DC\ link}=600V$ (DC), $V_{mot}=425V$ rms

3.2 Speed-torque diagrams 1FK7 CT

Table 3-11 1FK7103 CT

Technical data	Code	Units	-5AF71	
Engineering data				
Rated speed	n_N	RPM	3000	
Pole number	$2p$		8	
Rated torque (100 K)	$M_{N(100\text{ K})}$	Nm	14	
Rated current	I_N	A	12	
Stall torque (60K)	$M_{0(60\text{ K})}$	Nm	30	
Stall torque (100K)	$M_{0(100\text{ K})}$	Nm	36	
Stall current (60K)	$I_{0(60\text{ K})}$	A	22.8	
Stall current (100K)	$I_{0(100\text{ K})}$	A	27.5	
Moment of inertia (with brake)	J_{mot}	10^{-4} kgm ²	118	
Moment of inertia (without brake)	J_{mot}	10^{-4} kgm ²	105	
Optimum operating point				
Optimum speed	n_{opt}	RPM	2500	
Optimum power	P_{opt}	kW	5.37	
Limiting data				
Max. perm. speed (mechan.)	n_{max}	RPM	5000	
Max. torque	M_{max}	Nm	108	
Peak current	I_{max}	A	84	
Physical constants				
Torque constant	k_T	Nm/A	1.35	
Voltage constant	k_E	V/1000 RPM	86	
Winding resistance at 20°C	R_{ph}	Ohm	0.09	
Rotating field inductance	L_D	mH	2.0	
Electrical time constant	T_{el}	ms	22.2	
Shaft torsional stiffness	C_t	Nm/rad	149000	
Mechanical time constant	T_{mech}	ms	1.55	
Thermal time constant	T_{th}	min	65	
Weight with brake	m	kg	32	
Weight without brake	m	kg	29	

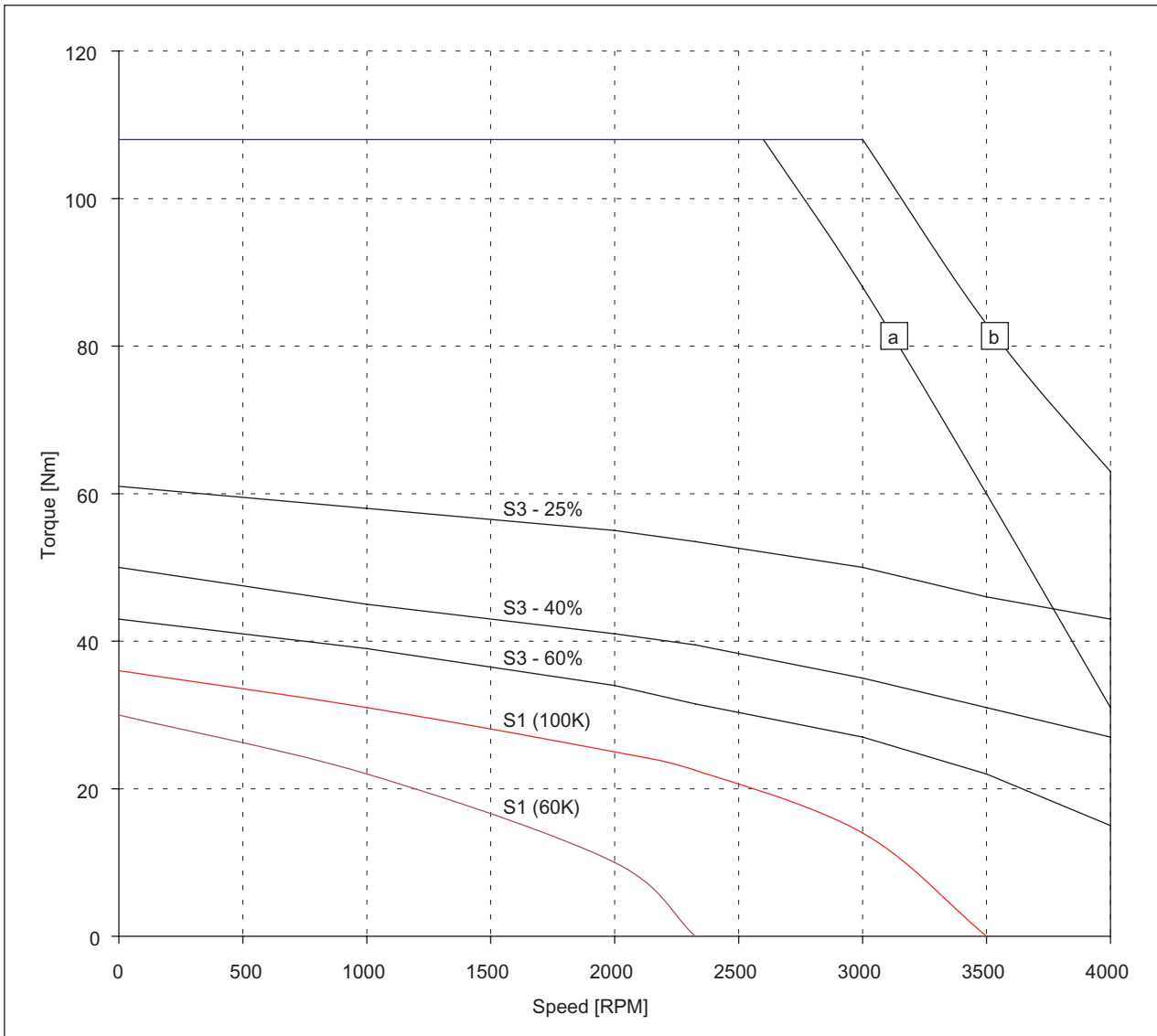

Figure 3-16 Speed-torque diagram 1FK7103-5AF71 CT

[a] SINAMICS S120 SMART LINE $V_{DC\ link}=540V$ (DC), $V_{mot}=380V$ rms
 [b] SINAMICS S120 ACTIVE LINE $V_{DC\ link}=600V$ (DC), $V_{mot}=425V$ rms

3.2 Speed-torque diagrams 1FK7 CT

Table 3-12 1FK7105 CT

Technical data	Code	Units	-5AC7	-5AF7
Engineering data				
Rated speed	n_N	RPM	2000	3000
Pole number	$2p$		8	8
Rated torque (100 K)	$M_{N(100\text{ K})}$	Nm	37	26
Rated current	I_N	A	16	18
Stall torque (60K)	$M_{0(60\text{ K})}$	Nm	40	40
Stall torque (100K)	$M_{0(100\text{ K})}$	Nm	48	48
Stall current (60K)	$I_{0(60\text{ K})}$	A	17	25
Stall current (100K)	$I_{0(100\text{ K})}$	A	20	31
Moment of inertia (with brake)	J_{mot}	10^{-4} kgm ²	169	169
Moment of inertia (without brake)	J_{mot}	10^{-4} kgm ²	156	156
Optimum operating point				
Optimum speed	n_{opt}	RPM	3000	3000
Optimum power	P_{opt}	kW	8.17	8.17
Limiting data				
Max. perm. speed (mechan.)	n_{max}	RPM	5000	5000
Max. torque	M_{max}	Nm	150	150
Peak current	I_{max}	A	72	109
Physical constants				
Torque constant	k_T	Nm/A	2.37	1.57
Voltage constant	k_E	V/1000 RPM	151	100
Winding resistance at 20°C	R_{ph}	Ohm	0.17	0.074
Rotating field inductance	L_D	mH	4.4	1.9
Electrical time constant	T_{el}	ms	26	26
Shaft torsional stiffness	C_t	Nm/rad	125000	125000
Mechanical time constant	T_{mech}	ms	14.2	14.1
Thermal time constant	T_{th}	min	70	70
Weight with brake	m	kg	41.5	41.5
Weight without brake	m	kg	39.1	39.1

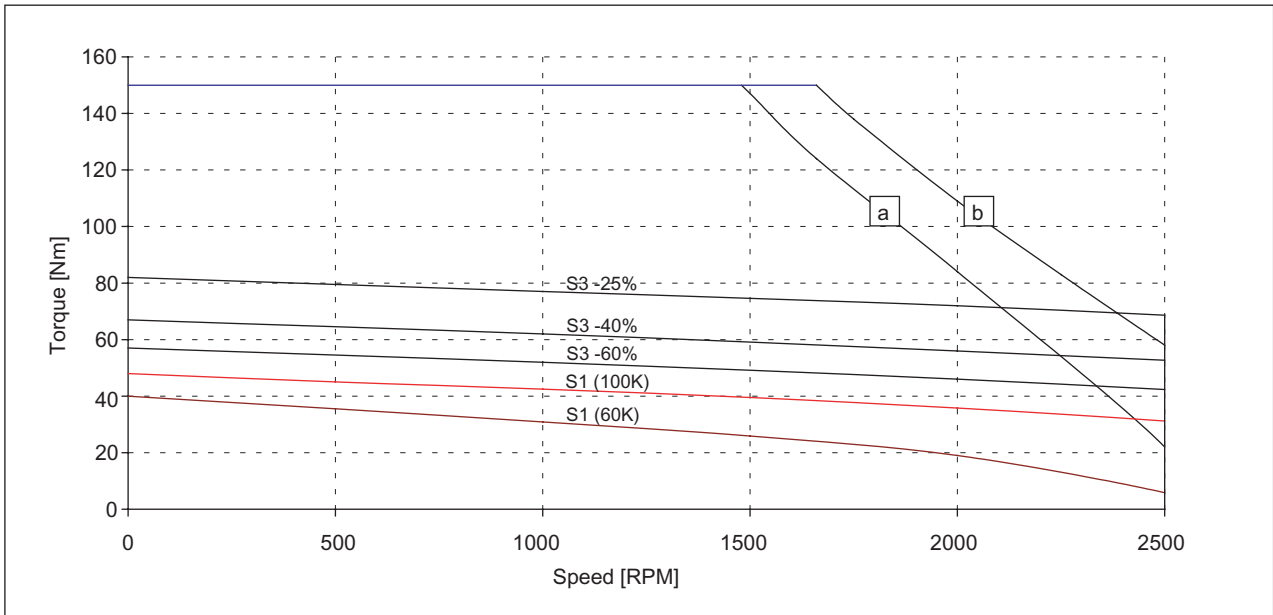

Figure 3-17 Speed-torque diagram 1FK7105-5AC7 CT

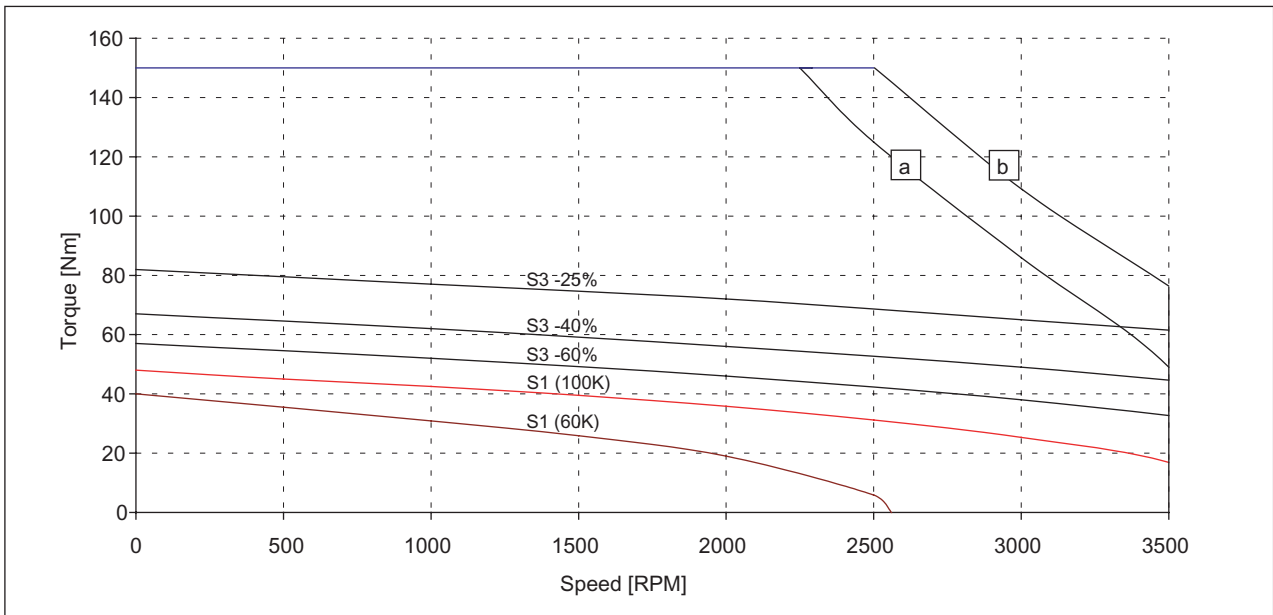

Figure 3-18 Speed-torque diagram 1FK7105-5AC7 CT

[a] SINAMICS S120 SMART LINE $V_{DC\ link}=540V$ (DC), $V_{mot}=380V$ rms
 [b] SINAMICS S120 ACTIVE LINE $V_{DC\ link}=600V$ (DC), $V_{mot}=425V$ rms

3.3 Speed-torque diagrams 1FK7 HD

Table 3-13 1FK7033 HD

Technical data	Code	Units	-7AK71	
Engineering data				
Rated speed	n_N	RPM	6000	
Pole number	2p		6	
Rated torque (100 K)	$M_{N(100 K)}$	Nm	0.9	
Rated current	I_N	A	1.5	
Stall torque (60K)	$M_0(60 K)$	Nm	1.0	
Stall torque (100K)	$M_0(100 K)$	Nm	1.3	
Stall current (60K)	$I_{0(60 K)}$	A	1.7	
Stall current (100K)	$I_{0(100 K)}$	A	2.2	
Moment of inertia (with brake)	J_{mot}	10^{-4} kgm^2	0.3	
Moment of inertia (without brake)	J_{mot}	10^{-4} kgm^2	0.27	
Optimum operating point				
Optimum speed	n_{opt}	RPM	6000	
Optimum power	P_{opt}	kW	0.56	
Limiting data				
Max. perm. speed (mechan.)	n_{max}	RPM	10000	
Max. torque	M_{max}	Nm	4.3	
Peak current	I_{max}	A	7.2	
Physical constants				
Torque constant	k_T	Nm/A	0.6	
Voltage constant	k_E	V/1000 RPM	40	
Winding resistance at 20°C	R_{ph}	Ohm	3.7	
Rotating field inductance	L_D	mH	18	
Electrical time constant	T_{el}	ms	4.9	
Shaft torsional stiffness	C_t	Nm/rad	8000	
Mechanical time constant	T_{mech}	ms	0.83	
Thermal time constant	T_{th}	min	25	
Weight with brake	m	kg	3.4	
Weight without brake	m	kg	3.1	

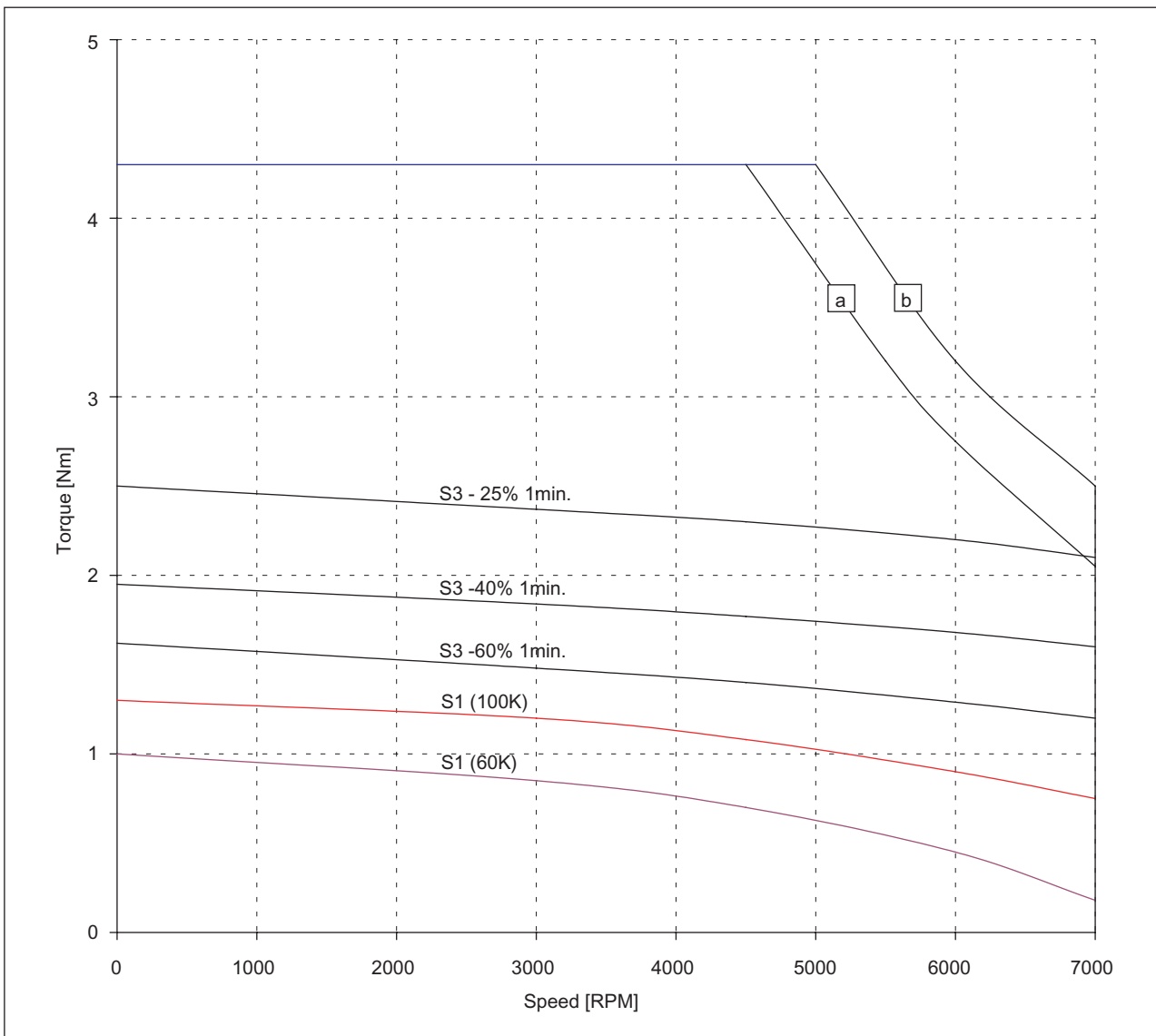

Figure 3-19 Speed-torque diagram 1FK7033-7AK71 HD

- [a] SINAMICS S120 SMART LINE $V_{DC\ link}=540V\ (DC)$, $V_{mot}=380V_{rms}$
- [b] SINAMICS S120 ACTIVE LINE $V_{DC\ link}=600V\ (DC)$, $V_{mot}=425V_{rms}$

3.3 Speed-torque diagrams 1FK7 HD

Table 3-14 1FK7043 HD

Technical data	Code	Units	-7AH71	-7AK71
Engineering data				
Rated speed	n_N	RPM	4500	6000
Pole number	$2p$		6	6
Rated torque (100 K)	$M_{N(100 K)}$	Nm	2.6	2
Rated current	I_N	A	4.0	4.4
Stall torque (60K)	$M_{0(60 K)}$	Nm	2.5	2.5
Stall torque (100K)	$M_{0(100 K)}$	Nm	3.1	3.1
Stall current (60K)	$I_{0(60 K)}$	A	3.6	4.8
Stall current (100K)	$I_{0(100 K)}$	A	4.5	6.4
Moment of inertia (with brake)	J_{mot}	10^{-4} kgm ²	1.14	1.14
Moment of inertia (without brake)	J_{mot}	10^{-4} kgm ²	1.01	1.01
Optimum operating point				
Optimum speed	n_{opt}	RPM	4500	6000
Optimum power	P_{opt}	kW	1.23	1.26
Limiting data				
Max. perm. speed (mechan.)	n_{max}	RPM	8000	8000
Max. torque	M_{max}	Nm	9.4	9.4
Peak current	I_{max}	A	14.8	20
Physical constants				
Torque constant	k_T	Nm/A	0.67	0.48
Voltage constant	k_E	V/1000 RPM	44	32
Winding resistance at 20°C	R_{ph}	Ohm	1.2	0.65
Rotating field inductance	L_D	mH	15	9
Electrical time constant	T_{el}	ms	12.5	13.8
Shaft torsional stiffness	C_t	Nm/rad	11000	11000
Mechanical time constant	T_{mech}	ms	0.81	0.85
Thermal time constant	T_{th}	min	40	40
Weight with brake	m	kg	7.0	7.0
Weight without brake	m	kg	6.3	6.3

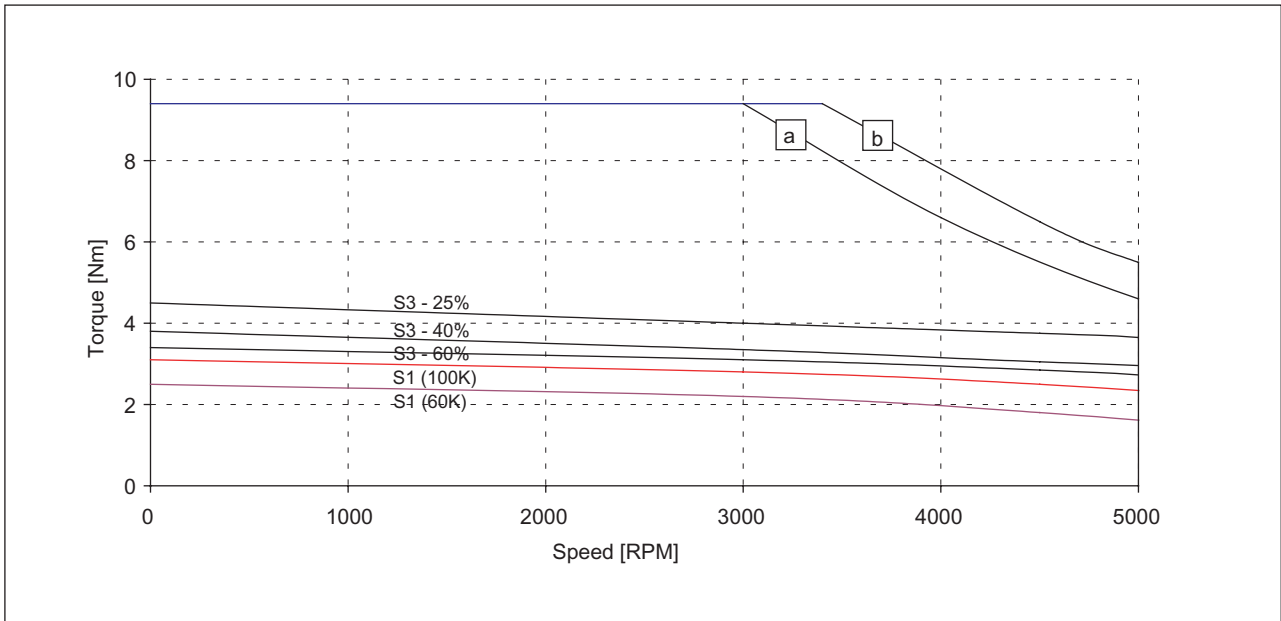

Figure 3-20 Speed-torque diagram 1FK7043-7AH71 HD

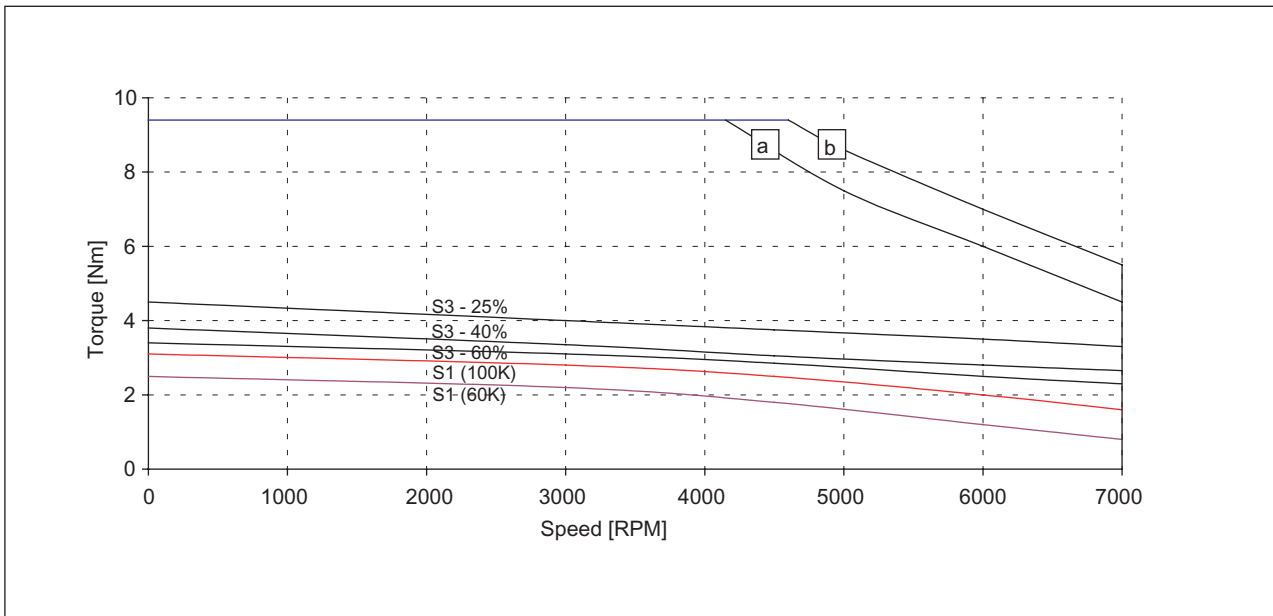

Figure 3-21 Speed-torque diagram 1FK7043-7AK71 HD

[a] SINAMICS S120 SMART LINE $V_{DC \text{ link}}=540V$ (DC), $V_{mot}=380V_{rms}$
 [b] SINAMICS S120 ACTIVE LINE $V_{DC \text{ link}}=600V$ (DC), $V_{mot}=425V_{rms}$

3.3 Speed-torque diagrams 1FK7 HD

Table 3-15 1FK7044 HD

Technical data	Code	Units	-7AF71	-7AH71
Engineering data				
Rated speed	n_N	RPM	3000	4500
Pole number	2p		6	6
Rated torque (100 K)	$M_{N(100\text{ K})}$	Nm	3.5	3.0
Rated current	I_N	A	4.0	4.9
Stall torque (60K)	$M_{0(60\text{ K})}$	Nm	3.0	3.0
Stall torque (100K)	$M_{0(100\text{ K})}$	Nm	4.0	4.0
Stall current (60K)	$I_{0(60\text{ K})}$	A	3.4	4.6
Stall current (100K)	$I_{0(100\text{ K})}$	A	4.5	6.3
Moment of inertia (with brake)	J_{mot}	10^{-4} kgm ²	1.41	1.41
Moment of inertia (without brake)	J_{mot}	10^{-4} kgm ²	1.28	1.28
Optimum operating point				
Optimum speed	n_{opt}	RPM	3000	4500
Optimum power	P_{opt}	kW	1.1	1.41
Limiting data				
Max. perm. speed (mechan.)	n_{max}	RPM	8000	8000
Max. torque	M_{max}	Nm	12	12
Peak current	I_{max}	A	14.8	20
Physical constants				
Torque constant	k_T	Nm/A	0.86	0.63
Voltage constant	k_E	V/1000 RPM	57	42
Winding resistance at 20°C	R_{ph}	Ohm	1.5	0.81
Rotating field inductance	L_D	mH	20	11
Electrical time constant	T_{el}	ms	13.3	13.5
Shaft torsional stiffness	C_t	Nm/rad	9500	9500
Mechanical time constant	T_{mech}	ms	0.78	0.78
Thermal time constant	T_{th}	min	45	45
Weight with brake	m	kg	8.3	8.3
Weight without brake	m	kg	7.7	7.7

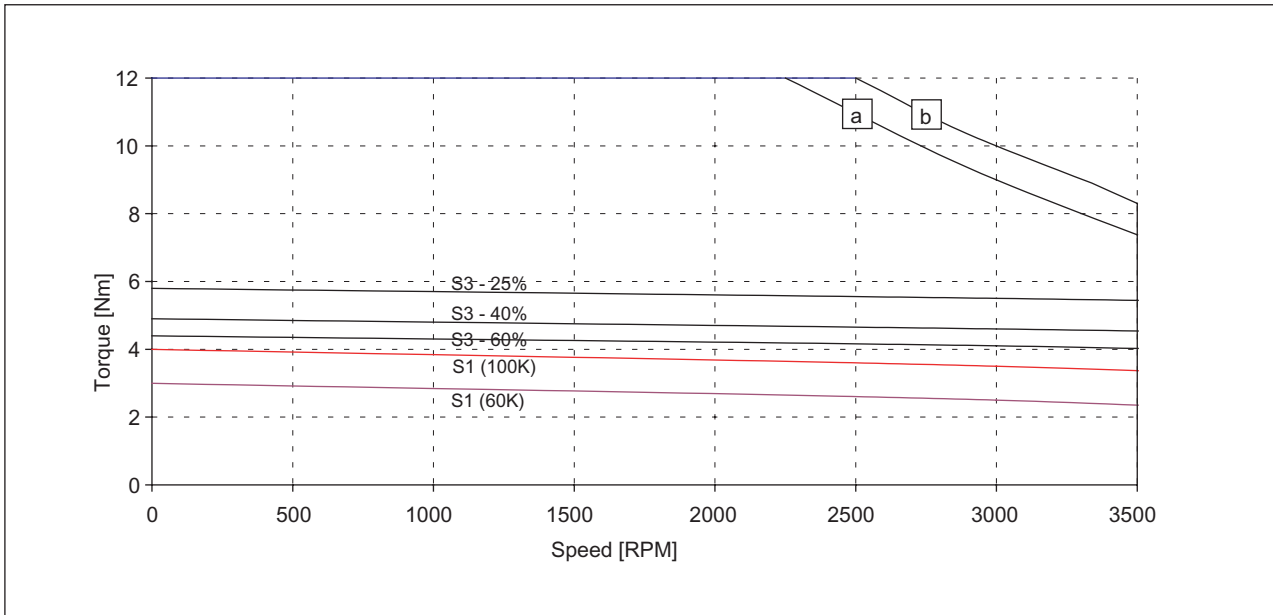

Figure 3-22 Speed-torque diagram 1FK7044-7AF71 HD

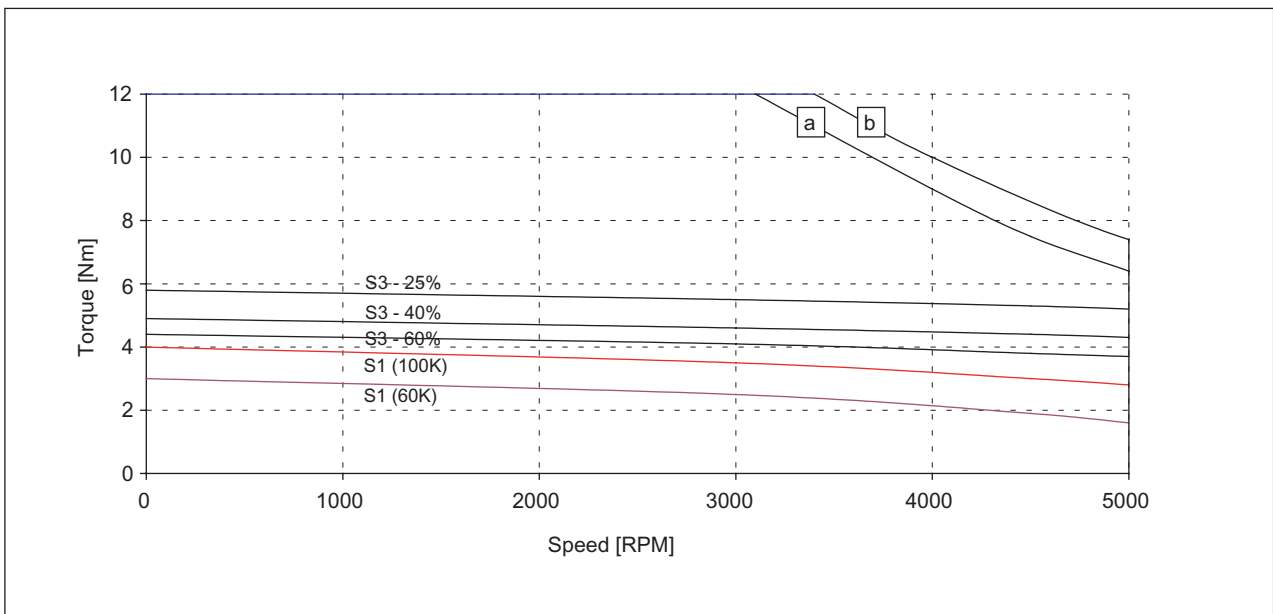

Figure 3-23 Speed-torque diagram 1FK7044-7AH71 HD

[a] SINAMICS S120 SMART LINE $V_{DC \text{ link}}=540V$ (DC), $V_{mot}=380V_{rms}$
 [b] SINAMICS S120 ACTIVE LINE $V_{DC \text{ link}}=600V$ (DC), $V_{mot}=425V_{rms}$

3.3 Speed-torque diagrams 1FK7 HD

Table 3-16 1FK7061 HD

Technical data	Code	Units	-7AF71	-7AH71
Engineering data				
Rated speed	n_N	RPM	3000	4500
Pole number	2p		6	6
Rated torque (100 K)	$M_{N(100 K)}$	Nm	5.4	4.3
Rated current	I_N	A	5.3	5.9
Stall torque (60K)	$M_0(60 K)$	Nm	4.9	4.9
Stall torque (100K)	$M_0(100 K)$	Nm	6.4	6.4
Stall current (60K)	$I_0(60 K)$	A	4.8	7.0
Stall current (100K)	$I_0(100 K)$	A	6.1	8.0
Moment of inertia (with brake)	J_{mot}	10^{-4} kgm ²	3.74	3.74
Moment of inertia (without brake)	J_{mot}	10^{-4} kgm ²	3.4	3.4
Optimum operating point				
Optimum speed	n_{opt}	RPM	3000	4500
Optimum power	P_{opt}	kW	1.7	2.03
Limiting data				
Max. perm. speed (mechan.)	n_{max}	RPM	6000	6000
Max. torque	M_{max}	Nm	17.3	17.3
Peak current	I_{max}	A	17.5	25.3
Physical constants				
Torque constant	k_T	Nm/A	1.0	0.7
Voltage constant	k_E	V/1000 RPM	66	46
Winding resistance at 20°C	R_{ph}	Ohm	0.74	0.36
Rotating field inductance	L_D	mH	20	9.6
Electrical time constant	T_{el}	ms	27	27
Shaft torsional stiffness	C_t	Nm/rad	37000	37000
Mechanical time constant	T_{mech}	ms	0.75	0.75
Thermal time constant	T_{th}	min	45	45
Weight with brake	m	kg	11.2	11.2
Weight without brake	m	kg	10	10

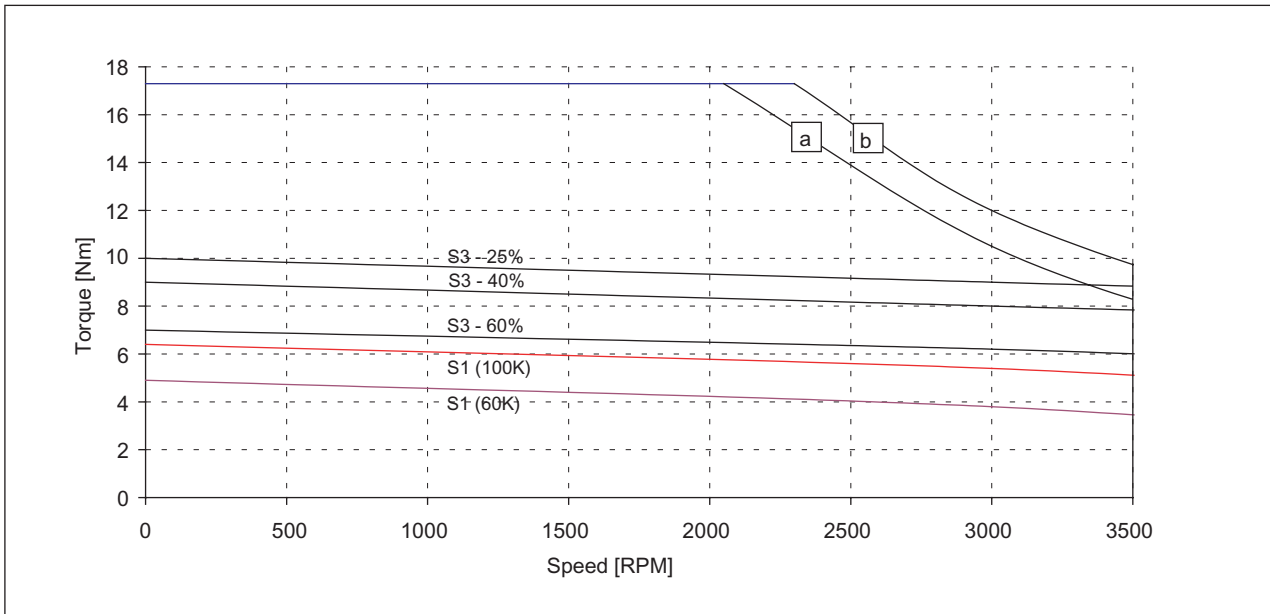

Figure 3-24 Speed-torque diagram 1FK7061-7AF71 HD

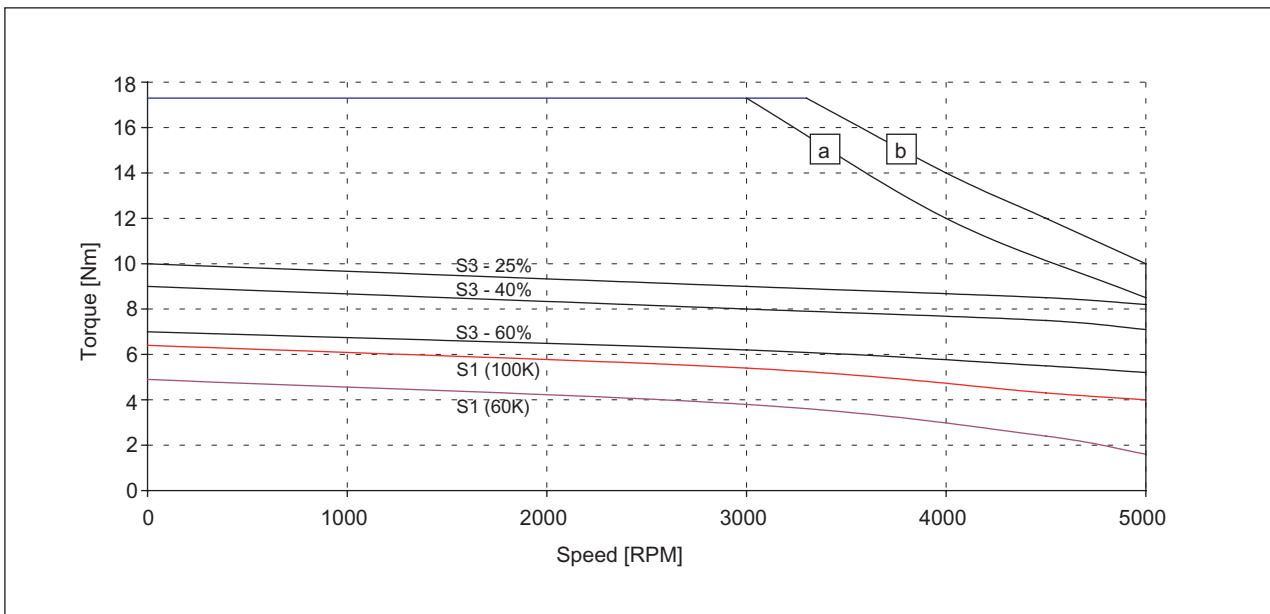

Figure 3-25 Speed-torque diagram 1FK7061-7AH71 HD

- [a] SINAMICS S120 SMART LINE $V_{DC \text{ link}}=540V \text{ (DC)}$, $V_{mot}=380V_{rms}$
- [b] SINAMICS S120 ACTIVE LINE $V_{DC \text{ link}}=600V \text{ (DC)}$, $V_{mot}=425V_{rms}$

3.3 Speed-torque diagrams 1FK7 HD

Table 3-17 1FK7064 HD

Technical data	Code	Units	-7AF71	-7AH71
Engineering data				
Rated speed	n_N	RPM	3000	4500
Pole number	$2p$		6	6
Rated torque (100 K)	$M_{N(100\text{ K})}$	Nm	8.0	5.0
Rated current	I_N	A	7.5	7.0
Stall torque (60K)	$M_{0(60\text{ K})}$	Nm	9.0	9.0
Stall torque (100K)	$M_{0(100\text{ K})}$	Nm	12	12
Stall current (60K)	$I_{0(60\text{ K})}$	A	8.5	12
Stall current (100K)	$I_{0(100\text{ K})}$	A	11	15
Moment of inertia (with brake)	J_{mot}	10^{-4} kgm ²	6.84	6.84
Moment of inertia (without brake)	J_{mot}	10^{-4} kgm ²	6.5	6.5
Optimum operating point				
Optimum speed	n_{opt}	RPM	3000	3500
Optimum power	P_{opt}	kW	2.51	2.75
Limiting data				
Max. perm. speed (mechan.)	n_{max}	RPM	6000	6000
Max. torque	M_{max}	Nm	32	32
Peak current	I_{max}	A	31	42
Physical constants				
Torque constant	k_T	Nm/A	1.03	0.77
Voltage constant	k_E	V/1000 RPM	68	51
Winding resistance at 20°C	R_{ph}	Ohm	0.35	0.18
Rotating field inductance	L_D	mH	10.7	5.6
Electrical time constant	T_{el}	ms	30.5	31.1
Shaft torsional stiffness	C_t	Nm/rad	30000	30000
Mechanical time constant	T_{mech}	ms	0.64	0.59
Thermal time constant	T_{th}	min	55	55
Weight with brake	m	kg	16.8	16.8
Weight without brake	m	kg	15.5	15.5

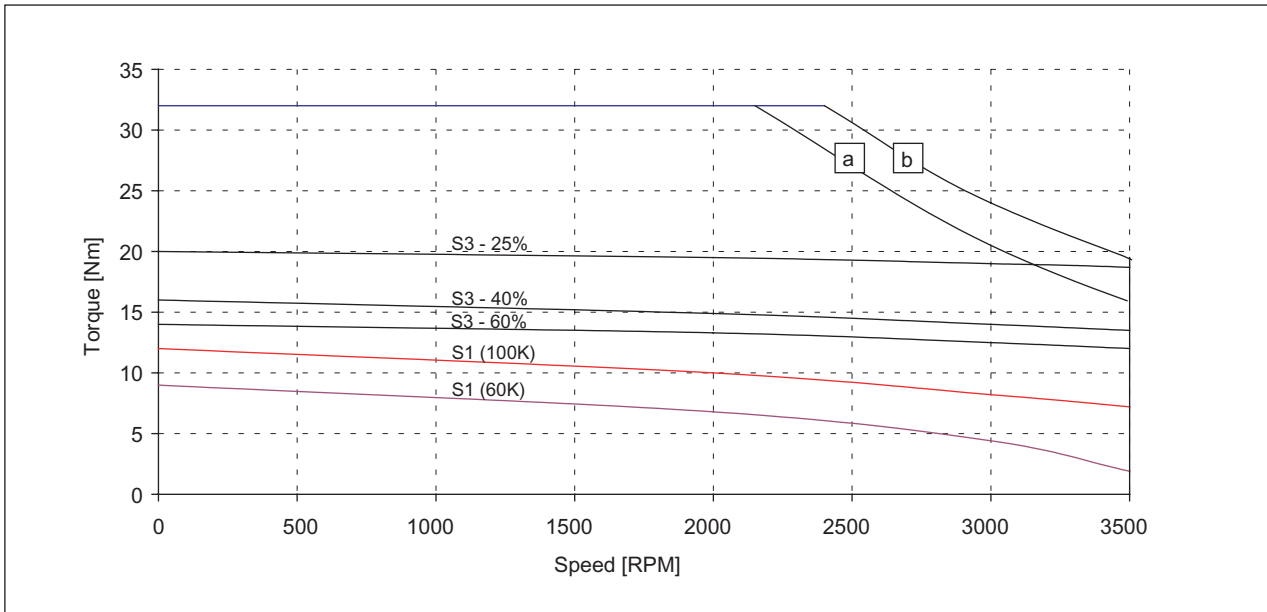

Figure 3-26 Speed-torque diagram 1FK7064-7AF71 HD

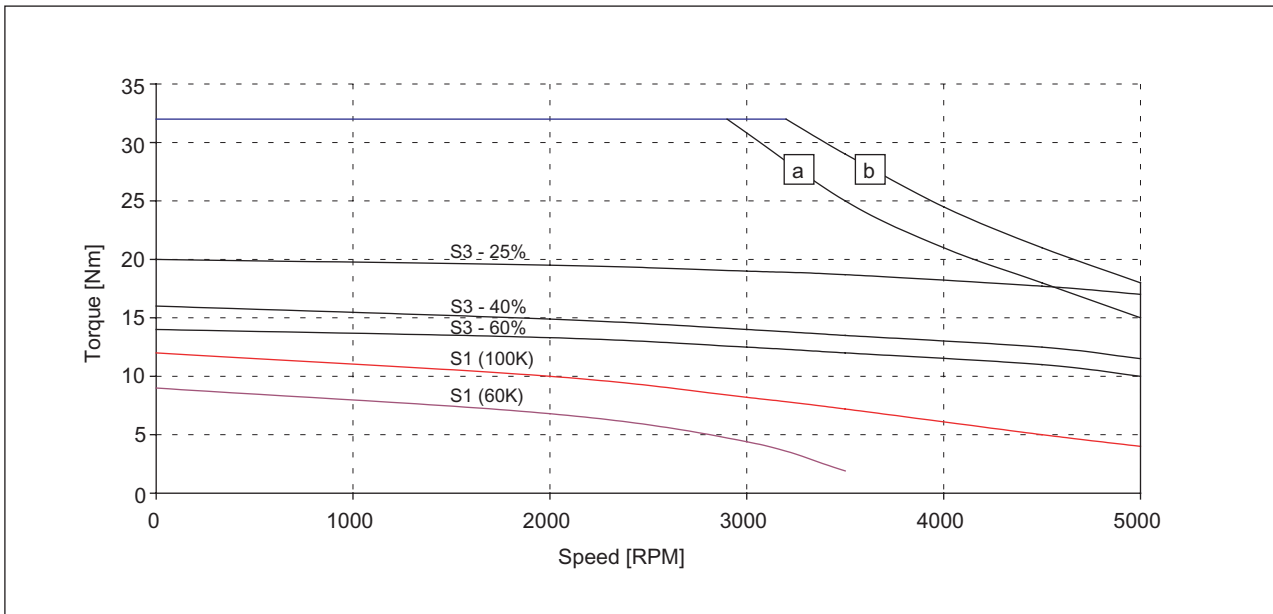

Figure 3-27 Speed-torque diagram 1FK7064-7AH71 HD

- [a] SINAMICS S120 SMART LINE $V_{DC\ link}=540V\ (DC)$, $V_{mot}=380V_{rms}$
- [b] SINAMICS S120 ACTIVE LINE $V_{DC\ link}=600V\ (DC)$, $V_{mot}=425V_{rms}$

3.3 Speed-torque diagrams 1FK7 HD

Table 3-18 1FK7082 HD

Technical data	Code	Units	-7AF71	
Engineering data				
Rated speed	n_N	RPM	3000	
Pole number	$2p$		8	
Rated torque (100 K)	$M_{N(100\text{ K})}$	Nm	8.0	
Rated current	I_N	A	6.7	
Stall torque (60K)	$M_{0(60\text{ K})}$	Nm	10.5	
Stall torque (100K)	$M_{0(100\text{ K})}$	Nm	14	
Stall current (60K)	$I_{0(60\text{ K})}$	A	8.0	
Stall current (100K)	$I_{0(100\text{ K})}$	A	10.6	
Moment of inertia (with brake)	J_{mot}	10^{-4} kgm ²	16	
Moment of inertia (without brake)	J_{mot}	10^{-4} kgm ²	14	
Optimum operating point				
Optimum speed	n_{opt}	RPM	3000	
Optimum power	P_{opt}	kW	2.51	
Limiting data				
Max. perm. speed (mechan.)	n_{max}	RPM	6000	
Max. torque	M_{max}	Nm	40	
Peak current	I_{max}	A	36	
Physical constants				
Torque constant	k_T	Nm/A	1.33	
Voltage constant	k_E	V/1000 RPM	88	
Winding resistance at 20°C	R_{ph}	Ohm	0.43	
Rotating field inductance	L_D	mH	8	
Electrical time constant	T_{el}	ms	23.2	
Shaft torsional stiffness	C_t	Nm/rad	101000	
Mechanical time constant	T_{mech}	ms	1.02	
Thermal time constant	T_{th}	min	60	
Weight with brake	m	kg	18.8	
Weight without brake	m	kg	17.2	

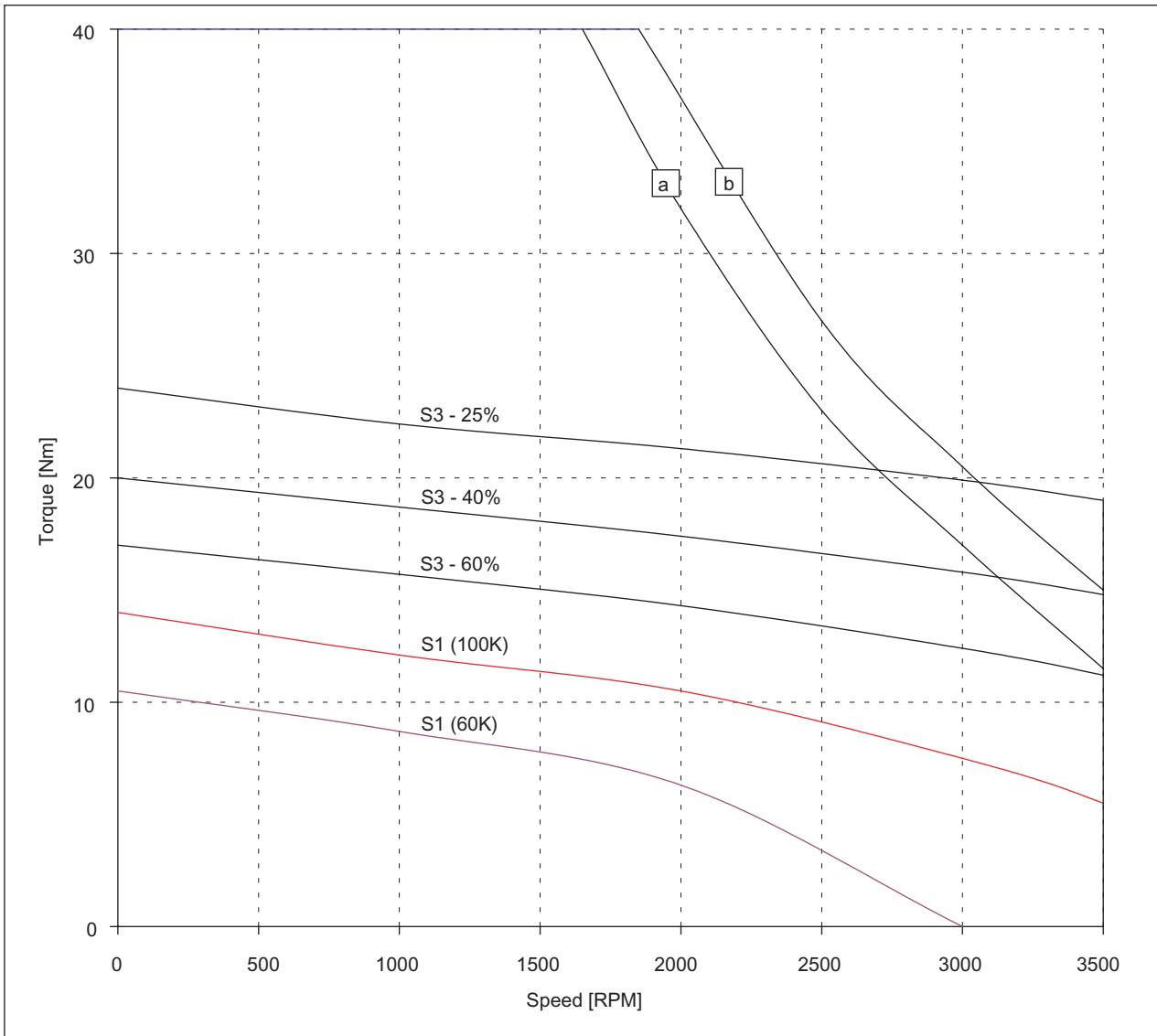

Figure 3-28 Speed-torque diagram 1FK7082-7AF71 HD

[a] SINAMICS S120 SMART LINE $V_{DC\ link}=540V\ (DC)$, $V_{mot}=380V_{rms}$
 [b] SINAMICS S120 ACTIVE LINE $V_{DC\ link}=600V\ (DC)$, $V_{mot}=425V_{rms}$

3.3 Speed-torque diagrams 1FK7 HD

Table 3-19 1FK7085 HD

Technical data	Code	Units	-7AF71	
Engineering data				
Rated speed	n_N	RPM	3000	
Pole number	$2p$		8	
Rated torque (100 K)	$M_{N(100 K)}$	Nm	6.5	
Rated current	I_N	A	7.0	
Stall torque (60K)	$M_{0(60 K)}$	Nm	17	
Stall torque (100K)	$M_{0(100 K)}$	Nm	22	
Stall current (60K)	$I_{0(60 K)}$	A	16.5	
Stall current (100K)	$I_{0(100 K)}$	A	22.5	
Moment of inertia (with brake)	J_{mot}	10^{-4} kgm ²	25	
Moment of inertia (without brake)	J_{mot}	10^{-4} kgm ²	23	
Optimum operating point				
Optimum speed	n_{opt}	RPM	2500	
Optimum power	P_{opt}	kW	3.14	
Limiting data				
Max. perm. speed (mechan.)	n_{max}	RPM	6000	
Max. torque	M_{max}	Nm	65	
Peak current	I_{max}	A	80	
Physical constants				
Torque constant	k_T	Nm/A	0.96	
Voltage constant	k_E	V/1000 RPM	63	
Winding resistance at 20°C	R_{ph}	Ohm	0.12	
Rotating field inductance	L_D	mH	3.3	
Electrical time constant	T_{el}	ms	27.5	
Shaft torsional stiffness	C_t	Nm/rad	83000	
Mechanical time constant	T_{mech}	ms	0.9	
Thermal time constant	T_{th}	min	65	
Weight with brake	m	kg	25.7	
Weight without brake	m	kg	23.5	

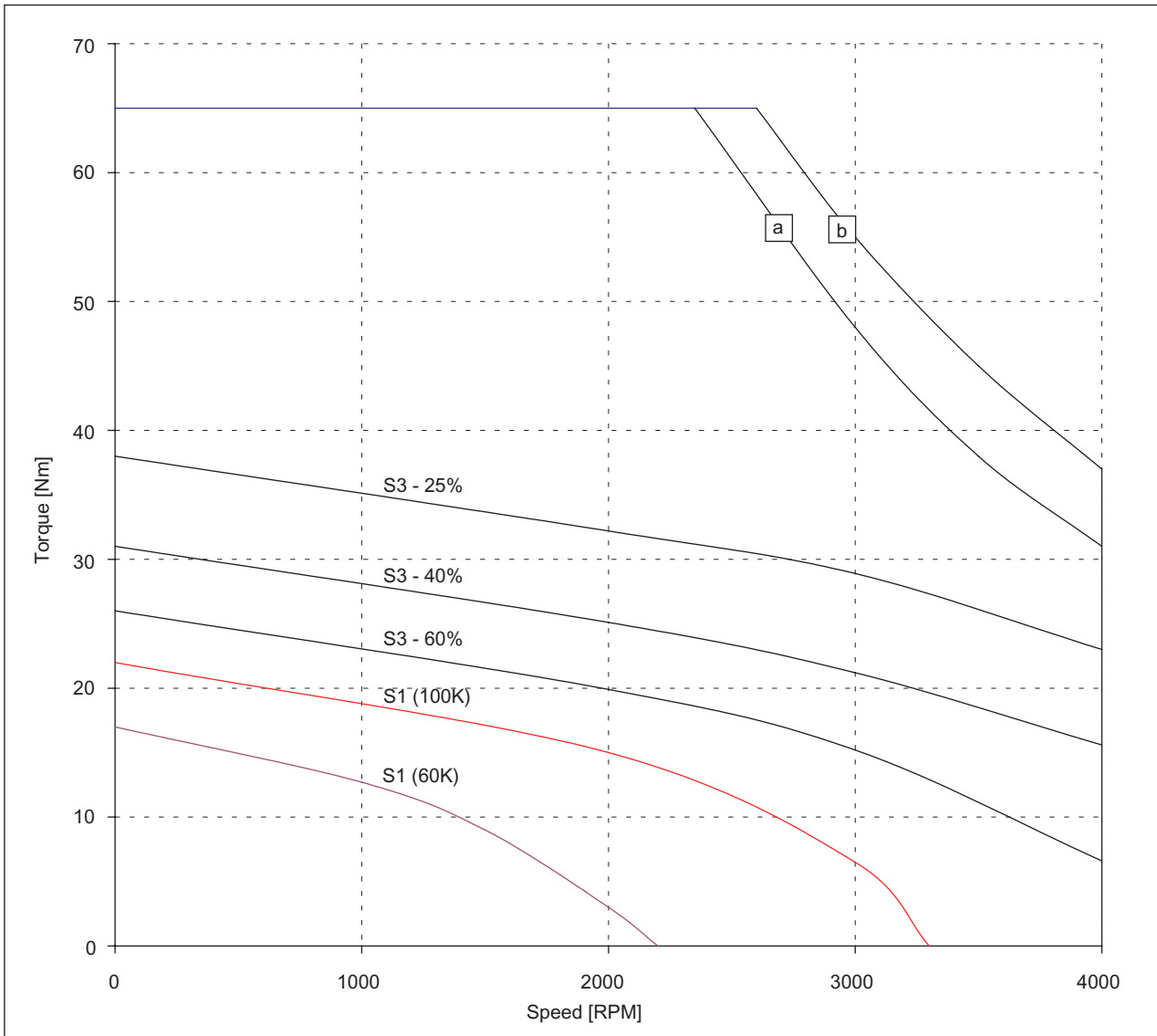

Figure 3-29 Speed-torque diagram 1FK7085-7AF71 HD

[a] SINAMICS S120 SMART LINE $V_{DC\ link}=540V\ (DC)$, $V_{mot}=380V_{rms}$
 [b] SINAMICS S120 ACTIVE LINE $V_{DC\ link}=600V\ (DC)$, $V_{mot}=425V_{rms}$

3.4 Cantilever force diagrams

Cantilever force stressing

Point of application of cantilever forces F_Q at the shaft end

- for average operating speeds
- for a nominal bearing lifetime of 20,000 h

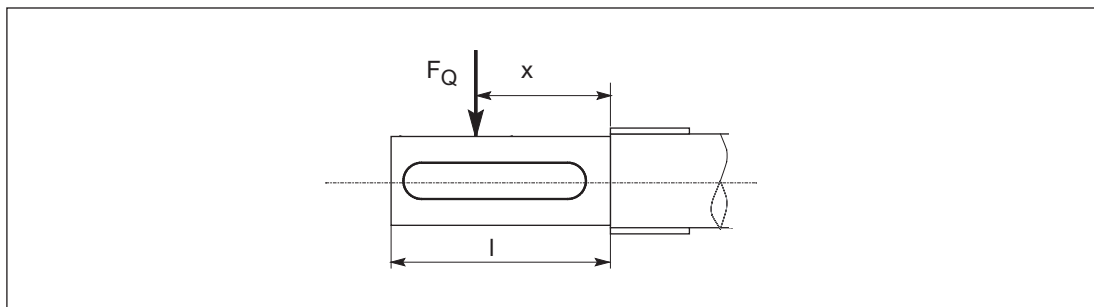

Figure 3-30 Force application point at the drive shaft end

Dimension x : Distance between the points of application of force F_Q and the shaft shoulder in mm.

Dimension l : Length of the shaft end in mm.

Calculating the pre-tensioned belt force

$$F_R = 2 * M_0 * c / d_R$$

Table 3-20 Explanation of the formula abbreviations

Formula abbreviations	Units	Description
F_R	N	Belt pre-tension
M_0	Nm	Motor stall torque
d_R	m	Effective diameter of the belt pulley
c	-	Pre-tensioning factor for the accelerating torque Empirical values for toothed belts: $c = 1.5$ to 2.2 Empirical values for flat belts: $c = 2.2$ to 3.0

For other designs, the actual forces should be taken into account from the torques to be transmitted.

$$F_R \leq F_{Qperm}$$

Cantilever force 1FK702

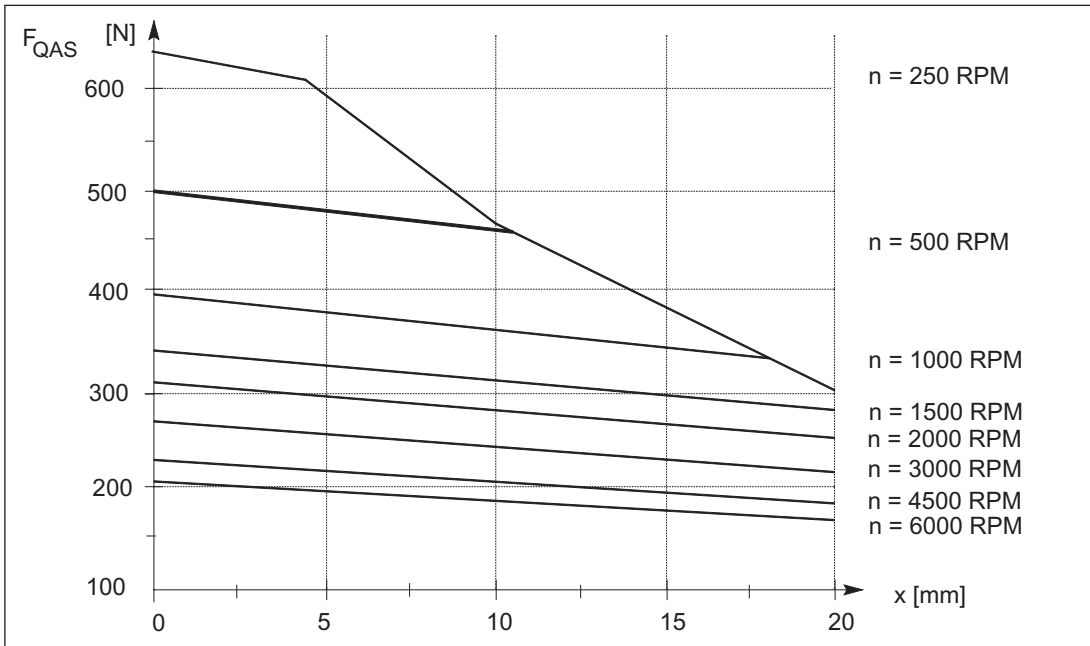

Figure 3-31 Cantilever force F_Q at a distance x from the shaft shoulder for a nominal bearing lifetime of 20,000 h.

Cantilever force 1FK703

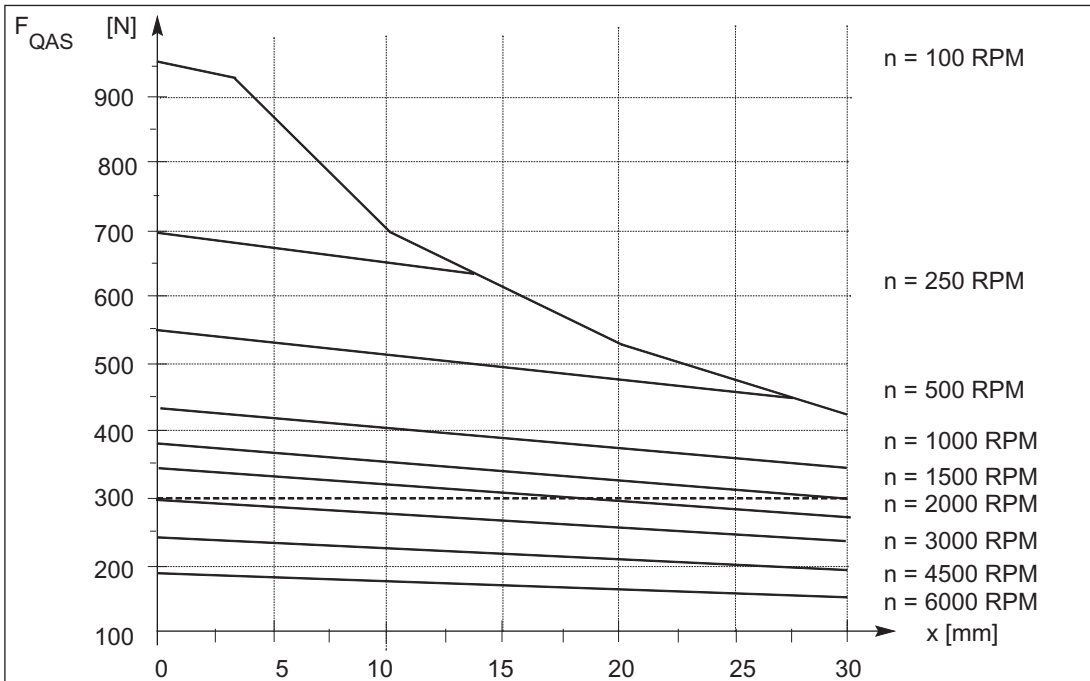

Figure 3-32 Cantilever force F_Q at a distance x from the shaft shoulder for a nominal bearing lifetime of 20,000 h.

3.4 Cantilever force diagrams

Cantilever force 1FK704

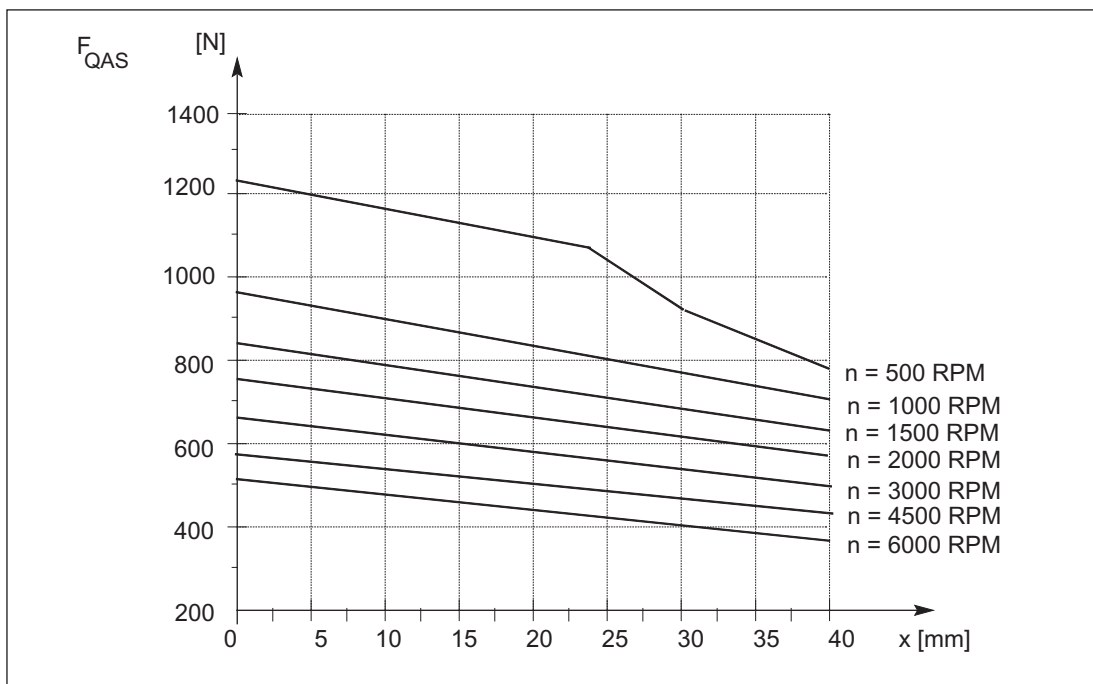

Figure 3-33 Cantilever force F_Q at a distance x from the shaft shoulder for a nominal bearing lifetime of 20,000 h.

Cantilever force 1FK706

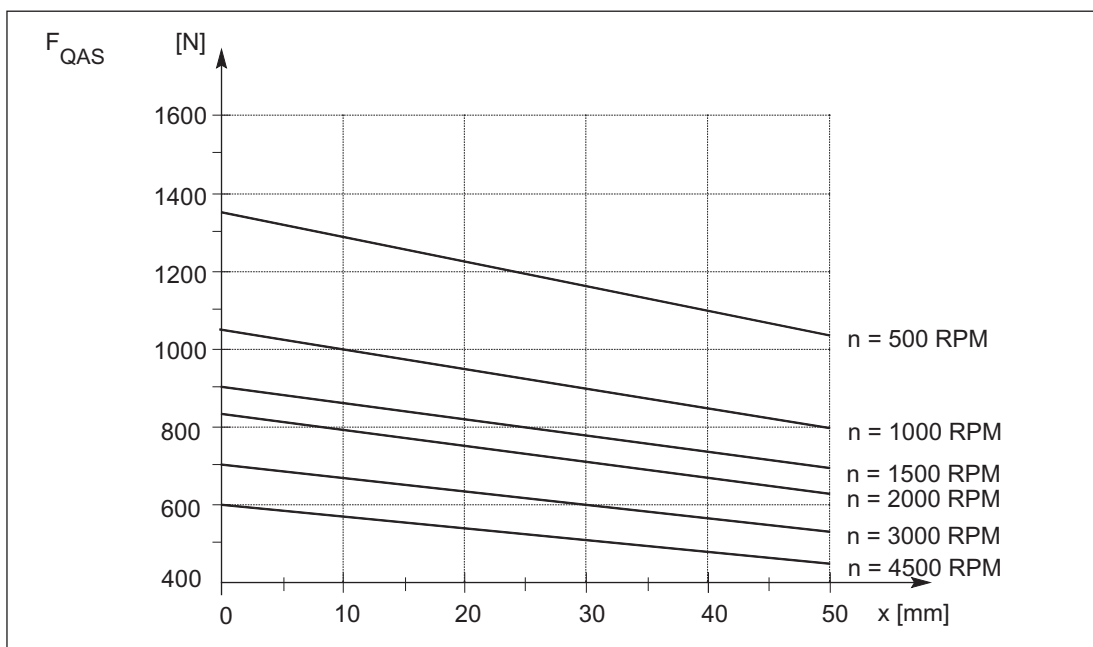

Figure 3-34 Cantilever force F_Q at a distance x from the shaft shoulder for a nominal bearing lifetime of 20,000 h.

Cantilever force 1FK708

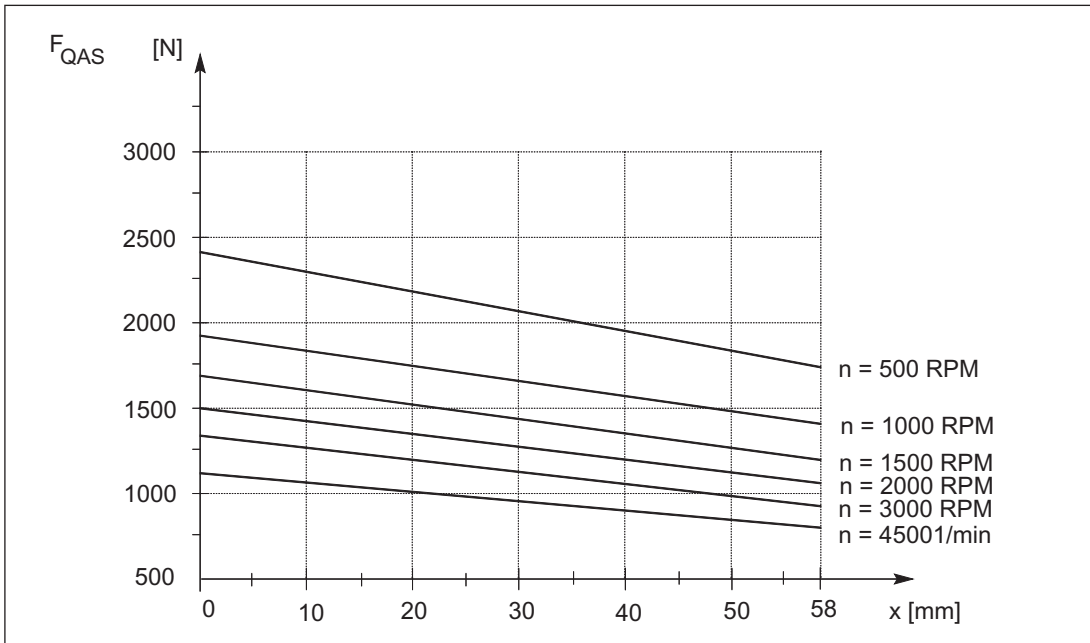

Figure 3-35 Cantilever force F_Q at a distance x from the shaft shoulder for a nominal bearing lifetime of 20,000 h.

Cantilever force 1FK710

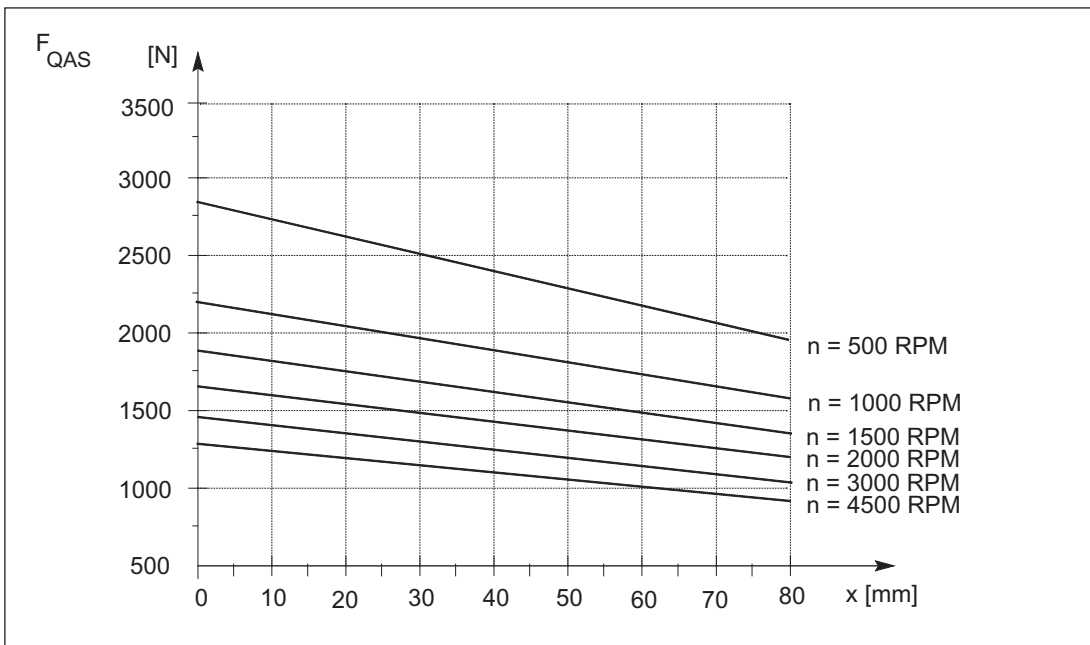

Figure 3-36 Cantilever force F_Q at a distance x from the shaft shoulder for a nominal bearing lifetime of 20,000 h.

3.5 Axial forces

Axial force stressing



Warning

Motors with integrated holding brake cannot be subject to axial forces!

When using, for example, helical toothed wheels as drive element, in addition to the radial force, there is also an axial force on the motor bearings. For axial forces, the spring-loading of the bearings can be overcome so that the rotor moves corresponding to the axial bearing play present (up to 0.2 mm).

The permissible axial force can be approximately calculated using the following formula:

$$F_A = 0.35 \cdot F_Q$$

Motor Components (Options)

4.1 Thermal motor protection

A temperature-dependent resistor is integrated as temperature sensor to monitor the motor temperature.

Table 4-1 Features and technical data

Type	KTY 84 (PTC thermistor)
Resistance when cold (20°C)	approx. 580 Ohm
Resistance when hot (100°C)	approx. 1000 Ohm
Connecting	via signal cable
Response temperature	Pre-warning at 120 °C ± 5 °C Alarm/trip at 145 °C ± 5 °C

The resistance of the KTY 84 thermistor changes proportionally to the winding temperature change.

The temperature signal is sensed and evaluated in the drive converter whose closed-loop control takes into account the temperature characteristic of the motor resistances.

When a fault occurs, an appropriate message is output at the drive converter. When the motor temperature increases, a message "Alarm motor overtemperature" is output; this must be externally evaluated. If this signal is not observed, the drive converter shuts down with the appropriate fault message when the motor limiting temperature or the shutdown temperature is exceeded.



Warning

If the user carries-out an additional high-voltage test, then the ends of the temperature sensor cables must be short-circuited before the test is carried-out!

If the test voltage is connected to a temperature sensor terminal, then it will be destroyed.

The polarity must be carefully observed.

The temperature sensor is designed so that the DIN/EN requirement for "protective separation" is fulfilled.



Caution

The integrated temperature sensor protects the synchronous against an overload condition

Shaft heights, 28 to 48 up to $2 \cdot I_{060K}$ and speed $\neq 0$

from shaft height 63 up to $4 \cdot I_{060K}$ and speed $\neq 0$

For load applications that are critical from a thermal perspective - e.g. overload when the motor is stationary or an overload of $4 \cdot M_0$ longer than 4 s, adequate protection is no longer available. This is the reason that additional protection must be provided.

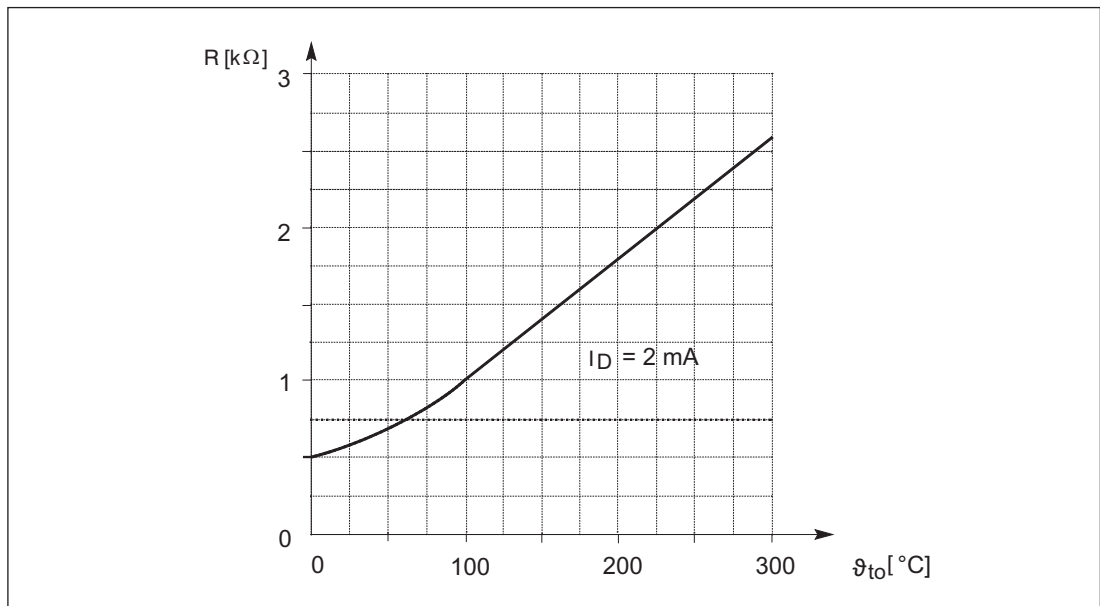

Figure 4-1 Resistance characteristic of the KTY 84 as a function of the temperature

4.2 Encoders

4.2.1 Encoder overview

The encoder is selected in the motor Order No. (MLFB) using the appropriate letter at the 14th position.

Note

The letter ID at the 14th position of the Order No. (MLFB) differs for motors with an without DRIVE-CLiQ.

Table 4-2 Encoder for motor with and without DRIVE-CLiQ

Motor types	Incremental encoders sin/cos 1 Vpp (for low shaft heights) (I-2048)	Incremental encoders sin/cos 1 Vpp (I-2048)	Absolute value encoders EnDat (A-2048)	Absolute value encoders EnDat (A-512)	Simple absolute value encoders (A-32)	Resolvers 2-pole/ multi-pole
Order No. (MLFB) 14th position for motors with DRIVE-CLiQ	D	D	F	L	K	U/ P
Order No. (MLFB) 14th position for motors without DRIVE-CLiQ	A	A	E	H	G	S/ T
1FK7 02□	X			X		X
1FK7 03□	X			X		X
1FK7 04□		X	X		X	X
1FK7 06□		X	X		X	X
1FK7 08□		X	X		X	X
1FK7 10□		X	X		X	X

Notice

When the encoder is replaced, the position of the encoder system with respect to the motor EMF must be adjusted. Only qualified personnel may replace an encoder.

4.3 Motors with DRIVE-CLiQ

Motors with DRIVE-CLiQ have a sensor module that includes the encoder evaluation, the motor temperature sensing and an electronic rating plate.

This sensor module instead of the signal connector and has a 10-pin RJ45-plus socket.



Caution

The sensor module contains motor and encoder-specific data as well as an electronic rating plate. This is the reason that this sensor module may only be operated on the original motor - and may not be mounted onto other motors or replaced by a sensor module from other motors.

The sensor module has direct contact to components that can be destroyed by electrostatic discharge (ESDS). Neither hands nor tools that could be electrostatically charged may come into contact with the connections.

Cables

For all encoder types (incremental encoder, absolute value encoder, resolver), the same DRIVE-CLiQ cable is used.

The following cable should be used to connect an encoder:

Table 4-3 Prefabricated cable

6FX	□	002	-	□DC□□	-	□□□	0
	↓					↓↓↓	
	↓					Length	
		5 MOTION-CONNECT®500				Max. cable length 100 m	
		8 MOTION-CONNECT®800				Max. cable length 50 m	

Only prefabricated cables from Siemens (MOTION-CONNECT) may be used.

Additional technical data and length code, refer to Catalog, Chapter "MOTION-CONNECT connection system"

4.4 Motors without DRIVE-CLiQ

4.4.1 Incremental encoders

Function:

- Angular measuring system for commutation
- Speed actual value sensing
- Indirect incremental measuring system for the position control loop
- One zero pulse (reference mark) per revolution

Table 4-4 Technical data, incremental encoders sin/cos 1Vpp

Features	Incremental encoders sin/cos 1 Vpp (I-2048)	Incremental encoders sin/cos 1 Vpp (low SH) (I-2048)
Mech. limiting speed	15000 RPM	12000 RPM
Operating voltage	5V ± 5%	5V ± 5%
Current consumption	max. 150 mA	max. 150 mA
Resolution, incremental	2048	2048
Incremental signals	1 Vpp	1 Vpp
Angular error	± 40"	± 80"
C-D track (rotor position)	available	available

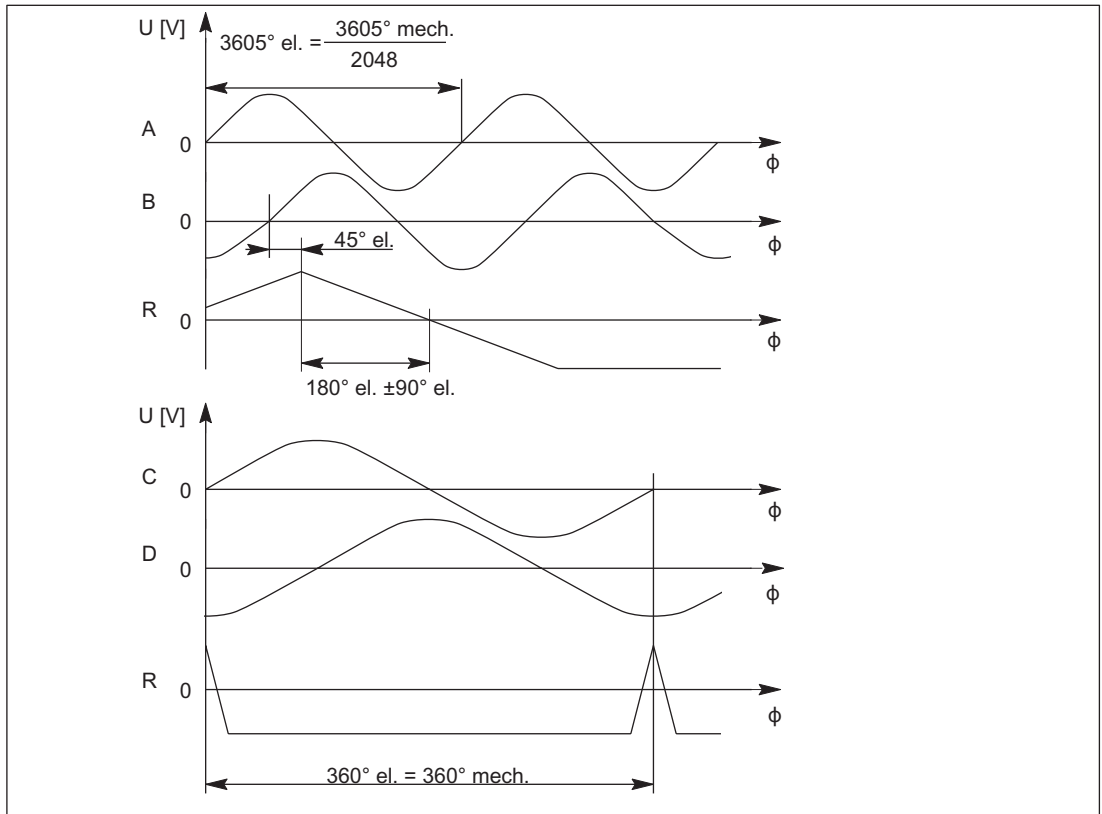
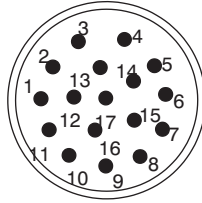

Figure 4-2 Signal sequence and assignment for a positive direction of rotation

Connection assignment for 17-pin flange-mounted socket with pin contacts

Table 4-5 Connection assignment for 17-pin flange-mounted socket

PIN No.	Signal	
1	A+	 <p>When viewing the plug-in side (pins)</p>
2	A-	
3	R+	
4	D-	
5	C+	
6	C-	
7	M encoder	
8	+Temp	
9	-Temp	
10	P encoder	
11	B+	
12	B-	
13	R-	
14	D+	
15	0 V sense	
16	5 V sense	
17	not connected	

Cables

Table 4-6 Prefabricated cable

6FX	□	002	-	2CA31	-	□□□	0
	↓					↓↓↓	
	↓					Length	
		5 MOTION-CONNECT@500				Max. cable length 100 m	
		8 MOTION-CONNECT@800					

Additional technical data and length code, refer to Catalog, Chapter "MOTION-CONNECT connection system"

4.4.2 Absolute value encoder

Function:

- Angular measuring system to impress the current
- Speed actual value sensing
- Absolute measuring system for the position control loop

Table 4-7 Technical data, absolute value encoder

Features	Absolute value encoder EnDat (A-2048)	Absolute value encoder EnDat (A-512)	Simple absolute value encoder (A-32)
Mech. limiting speed	12000 RPM	12000 RPM	12000 RPM
Operating voltage	5V ± 5%	5V ± 5%	5V ± 5%
Current consumption	max. 300 mA	max. 200 mA	max. 300 mA
Incremental resolution (periods per revolution)	2048	512	32
Absolute resolution (coded revolutions)	4096	4096	4096
Incremental signals	1 Vpp	1 Vpp	1 Vpp
Serial absolute position interface	EnDat	EnDat	EnDat
Angular error	± 40"	± 80"	± 400"

Note

The thermally permissible motor rated torque is reduced by 10% as a result of the reduced maximum operating temperature of the absolute value encoder with respect to incremental encoders.

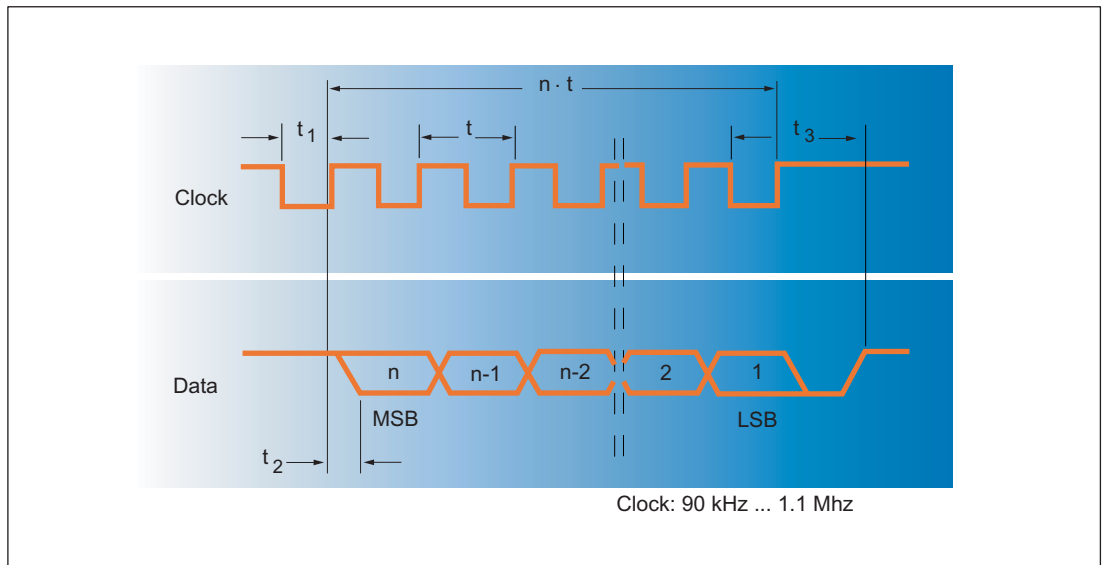
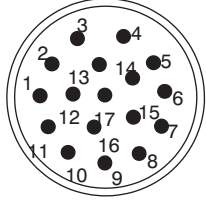

Figure 4-3 Output signals, absolute value encoders

Connection assignment for 17-pin flange-mounted socket with pin contacts

Table 4-8 Connection assignment for 17-pin flange-mounted socket

PIN No.	Signal	
1	A+	 <p>When viewing the plug-in side (pins)</p>
2	A-	
3	+ data	
4	not connected	
5	+clock	
6	not connected	
7	M encoder	
8	+Temp	
9	-Temp	
10	P encoder	
11	B+	
12	B-	
13	-Data	
14	-clock	
15	0 V sense	
16	5 V sense	
17	not connected	

Cables

Table 4-9 Prefabricated cable

6FX	□	002	-	2EQ10	-	□□□	0
	↓					↓↓↓	
	↓					Length	
		5 MOTION-CONNECT@500				Max. cable length 100 m	
		8 MOTION-CONNECT@800					

Additional technical data and length code, refer to Catalog, Chapter "MOTION-CONNECT connection system"

4.4.3 Resolvers

Notice

A max. operating frequency of 470 Hz must be maintained for SINAMICS S120.

Function:

- Speed actual value sensing
- Rotor position encoder for inverter control
- Indirect incremental measuring system for the position control loop

Table 4-10 Technical data, resolvers

Features	Resolvers
Mech. limiting speed	15 000 RPM
Excitation voltage	5 V (rms) to 13 V (rms)
Excitation frequency	4 kHz to 10 kHz
Current consumption	< 80 mA (rms)
Angular accuracy (bandwidth) 2-pole multi-pole	< 14' < 4'
Pole number (The pole number is identical with the motor pole number)	2, 4, 6 or 8
Ratio	0.5

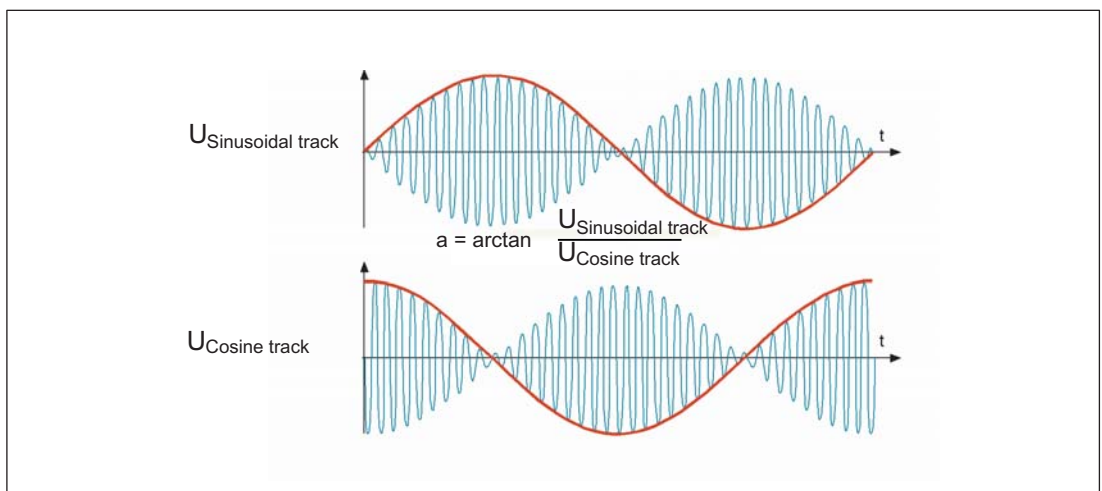
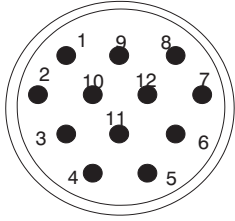

Figure 4-4 Output signals, resolver

Connection assignment for 12-pin flange-mounted socket with pin contacts

Table 4-11 Connection assignment for 12-pin flange-mounted socket

PIN No.	Signal	
1	S2	 <p>When viewing the plug-in side (pins)</p>
2	S4	
3	not connected	
4	not connected	
5	not connected	
6	not connected	
7	R2/R3	
8	+Temp	
9	-Temp	
10	R1	
11	S1	
12	S3	

Cables

Table 4-12 Prefabricated cable

6FX	□	002	-	2CF02	-	□□□	0
	↓					↓↓↓	
	↓					Length	
		5 MOTION-CONNECT®500				2-pole resolver: Max. cable length 50 m	
		8 MOTION-CONNECT®800				Multi-pole resolver: Max. cable length 130 m	

Additional technical data and length code, refer to Catalog, Chapter "MOTION-CONNECT connection system"

4.5 Holding brake (option)

For a description of the function, refer to the documentation "General Section for Synchronous motors".

Table 4-13 Technical data of the holding brakes used for 1FK7 motors

Motor type	Brake type	Holding torque M_4 ¹⁾	DC current	Opening time with varistor	Closing time with varistor	Highest switched energy
		[Nm]	[A]	[ms]	[ms]	[J]
1FK7 CT permanent-magnet brakes						
1FK7022	EBD 0.11 BN	1	0.3	30	20	8
1FK7032	EBD 0.13 BN	1.1	0.4	50	30	17
1FK704□	EBD 0.3 BV	3.2	0.6	70	30	74
1FK706□	EBD 0.8 BK	13	0.8	100	50	400
1FK7080	EBD 1.5 BN	10	0.8	100	50	400
1FK7083 1FK7100	EBD 2 BY	22	0.9	200	60	1400
1FK7101 1FK7103 1FK7105	EBD 3.5 BV	41	1.0	300	70	3000
1FK7 HD spring-operated brakes						
1FK7033	1EB 14-30	1.3	0.5	100	40	14
1FK704□	1EB 20-40	4	0.6	150	50	96
1FK706□	1EB 28-60	12	0.8	150	50	230
1FK708□	1EB 35-80	22	1.2	200	60	700

¹⁾ Standardized acc. to VDE 0580 with varistor circuit

Holding torque

The holding torque M_4 is the minimum brake torque in steady-state operation (when the motor is at a standstill).

4.6 Planetary gearbox (option)

Planetary gearboxes (alpha company, LP series) - selection table for 1FK7 motors

Table 4-14 Technical data of the planetary gearboxes which can be used for 1FK7 CT and 1FK7 HD motors

Servo-motor Non-ventilated Type	Planetary gearbox 1 stage Rotary play ≤ 12 arcmin Type	Gearbox weight approx. [kg]	Available gearbox ratios		Max. perm. input speed ¹⁾ n _{G1} [RPM]	Max. perm. output torque ¹⁾		Max. perm. drive-out shaft load ²⁾ F _r [N]	Moment of inertia Gear-boxes J _G at i = 5/10 [10 ⁻⁴ kgm ²]
			i = 5	i = 10		M _{G2} at i = 5 [Nm]	M _{G2} at i = 10 [Nm]		
1FK7022	LP050-M01	0.77	X	–	8000	11.5	10.5	650	0.059
1FK7022	LP070-M01	1.9	–	X	6000	32	29	1450	0.28
1FK7032	LP070-M01	1.9	X	X	6000	32	29	1450	0.28
1FK7033	LP070-M01	1.9	X	X	6000	32	29	1450	0.28
1FK7040	LP090-M01	4.1	X	X	6000	80	72	2400	1.77
1FK7042	LP090-M01	4.1	X	X	6000	80	72	2400	1.77
1FK7043	LP090-M01	4.1	X	X	6000	80	72	2400	1.77
1FK7044	LP090-M01	4.1	X	X	6000	80	72	2400	1.77
1FK7060	LP120-M01	9	X	X	4800	200	180	4600	5.42
1FK7061	LP120-M01	9	X	X	4800	200	180	4600	5.42
1FK7063	LP120-M01	9	X	X	4800	200	180	4600	5.42
1FK7064	LP120-M01	9	X	X ³⁾	4800	200	180	4600	5.42
1FK7080	LP155-M01	17.5	X	X	3600	400	320	7500	25.73
1FK7082	LP155-M01	17.5	X	X	3600	400	320	7500	25.73
1FK7083	LP155-M01	17.5	X	X	3600	400	320	7500	25.73
1FK7085	LP155-M01	17.5	X	X ³⁾	3600	400	320	7500	25.73
1FK7100	LP155-M01	17.5	X	–	3600	400	320	7500	25.73
1FK7101	LP155-M01	17.5	X	–	3600	400	320	7500	25.73
1FK7103	LP155-M01	17.5	X	–	3600	400	320	7500	25.73
1FK7105	LP155-M01	17.5	X	–	3600	400	320	7500	25.73
Code: Gearbox shaft with fitted key			V40	V42					

¹⁾ Values for cyclic/positioning operation S3 60% (switch-on duration < 60% or switch-on duration < 20 min)

²⁾ referred to the center of the drive-out shaft, at 100 RPM

³⁾ It is necessary to reduce the max. motor torque

Continuous duty S1

At the rated speed and rated torque, continuous duty is permissible. A gearbox temperature of 90° C may not be exceeded.

Table 4-15 Continuous duty S1

Planetary gearbox 1-stage Torsional play ≤12 arcmin	Rated speed [RPM]	Max. permissible output torque ¹⁾ [Nm]	
		M _{N2} at i = 5	M _{N2} at i = 10
Type	n _{N1}		
LP50-M01	4000	5.7	5.2
LP070-M01	3700	16	15
LP090-M01	3400	40	35
LP120-M01	2600	100	90
LP155-M01	2000	290	170

1) Values for cycle/positioning operation S3 60% (switch-on duration < 60% or switch-on duration < 20 min)

The gearboxes are suitable for every mounting position.
The gearboxes have an IP 64 degree of protection.
Gearboxes without key are not available.

Dimensions of 1FK7 CT/HD with planetary gearbox from the alpha company, series LP

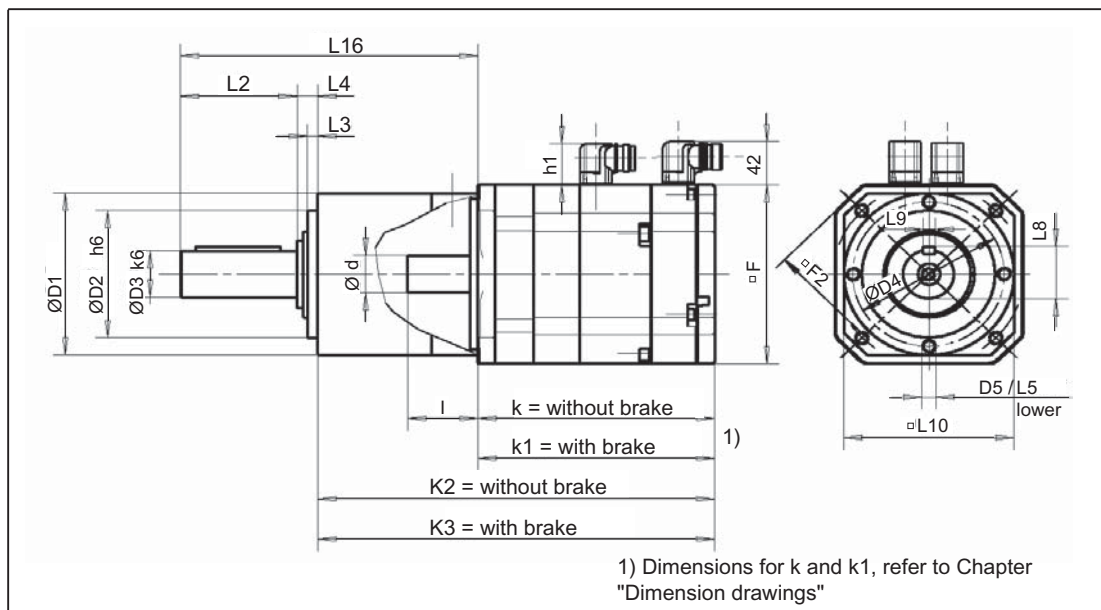

Figure 4-5 Dimensions 1FK7 CT and 1FK7 HD motor with planetary gearbox

Dimensions 1FK7 CT motor with planetary gearbox

Table 4-16 Dimensions 1FK7 CT motor with planetary gearbox

Servomotors	Dimensions [mm]		Planetary gearbox 1-stage	Dimensions without brake [mm]			Dimensions with brake [mm]		
	h1	□F		K2 2)	K2 3)	K2 4)	K3 2)	K3 3)	K3 4)
1FK7022	42	55	LP050-M01	216	241	241	238	263	263
1FK7022			LP070-M01	236	261	261	258	283	283
1FK7032	42	72	LP070-M01	240	265	265	265	290	290
1FK7040	42	96	LP090-M01	247	267	276	276	296	305
1FK7042				274	295	303	303	324	332
1FK7060	42	126	LP120-M01	297	320	328	340	363	371
1FK7063				342	365	373	385	408	416
1FK7080	42	155	LP155-M01	325	347	355	353	375	384
1FK7083				363	385	393	414	436	444
1FK7100	42	192	LP155-M01	374	396	404	393	415	423
1FK7101	64	192	LP155-M01	400	422	430	429	452	460
1FK7103				426	448	456	455	478	486
1FK7105				426	448	456	455	478	486

Table 4-17 Dimensions 1FK7 CT motor with planetary gearbox

Servomotors	Dimensions [mm]												
	∅ D1	∅ D2	∅ D3	∅ D4	D5	L16	L2	L3	L4	L5	L8	L9	L10
1FK7022	50	35	12	44	M4	88	18	4	7	8	14	4	50
1FK7022	70	52	16	62	M5	119	28	5	8	10	18	5	70
1FK7032	70	52	16	62	M6	126	28	5	8	10	18	5	70
1FK7040	90	68	22	80	M6	158	36	5	10	12	25	6	90
1FK7042													
1FK7060	120	90	32	108	M8	210	58	6	12	16	35	10	120
1FK7063													
1FK7080	155	120	40	140	M10	266	82	8	15	20	43	12	150
1FK7083													
1FK7100	155	120	40	140	M10	266	82	8	15	20	43	12	150
1FK7101	155	120	40	140	M10	266	82	8	15	20	43	12	150
1FK7103													
1FK7105													

Dimensions 1FK7 HD motor with planetary gearbox

Table 4-18 Dimensions 1FK7 HD motor with planetary gearbox

Servomotors	Dimensions [mm]		Planetary gearbox 1-stage	Dimensions without brake [mm]			Dimensions with brake [mm]		
	h1	□F		K2 2)	K2 3)	K2 4)	K3 2)	K3 3)	K3 4)
1FK7033	42	72	LP070-M01	260	285	285	285	310	310
1FK7043 1FK7044	42	96	LP090-M01	303 328	324 349	332 357	332 357	352 377	361 386
1FK7061 1FK7064	42	126	LP120-M01	325 389	348 412	357 421	368 432	391 455	400 464
1FK7082 1FK7085	42 64	155	LP155-M01	370 430	393 453	401 461	423 473	445 495	454 504

Table 4-19 Dimensions 1FK7 HD motor with planetary gearbox

Servomotors	Dimensions [mm]												
	∅ D1	∅ D2	∅ D3	∅ D4	D5	L16	L2	L3	L4	L5	L8	L9	L10
1FK7033	70	52	16	62	M5	126	28	5	8	10	18	5	70
1FK7043 1FK7044	90	68	22	80	M6	158	36	5	10	12	25	6	90
1FK7061 1FK7064	120	90	32	108	M8	210	58	6	12	16	35	10	120
1FK7082 1FK7085	155	120	40	140	M10	266	82	8	15	20	43	12	150

Dimension Drawings

5.1 Introduction

Note

Siemens AG reserves the right to change the dimensions of the motors as part of mechanical design improvements without prior notice. This means that dimensions drawings can go out-of-date. Up-to-date dimension drawings can be requested at no charge from your local SIEMENS sales department.

5.2 1FK7 CT with DRIVE-CLiQ

5.2 1FK7 CT with DRIVE-CLiQ

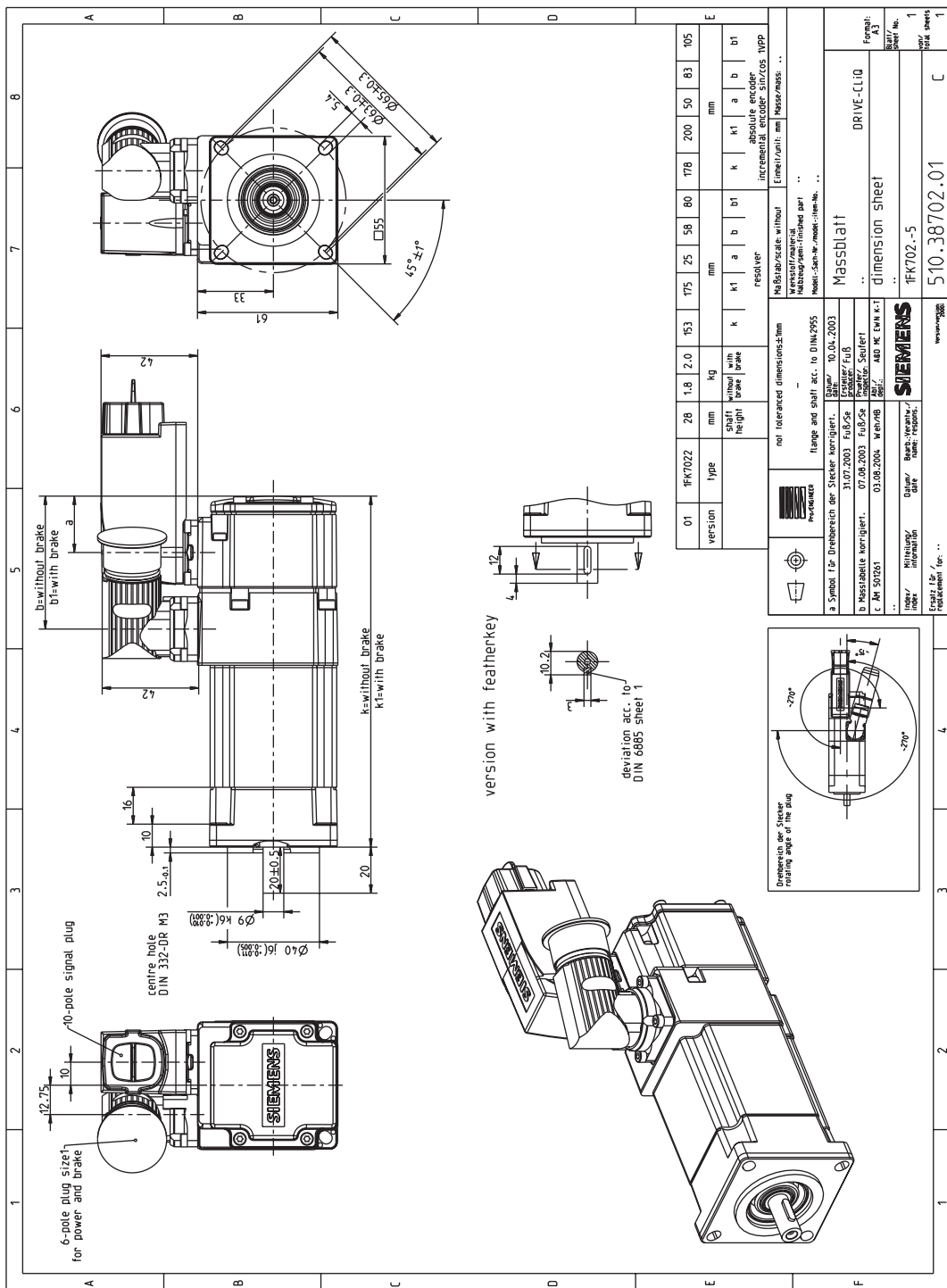

Figure 5-1 1FK702_5A_DQ

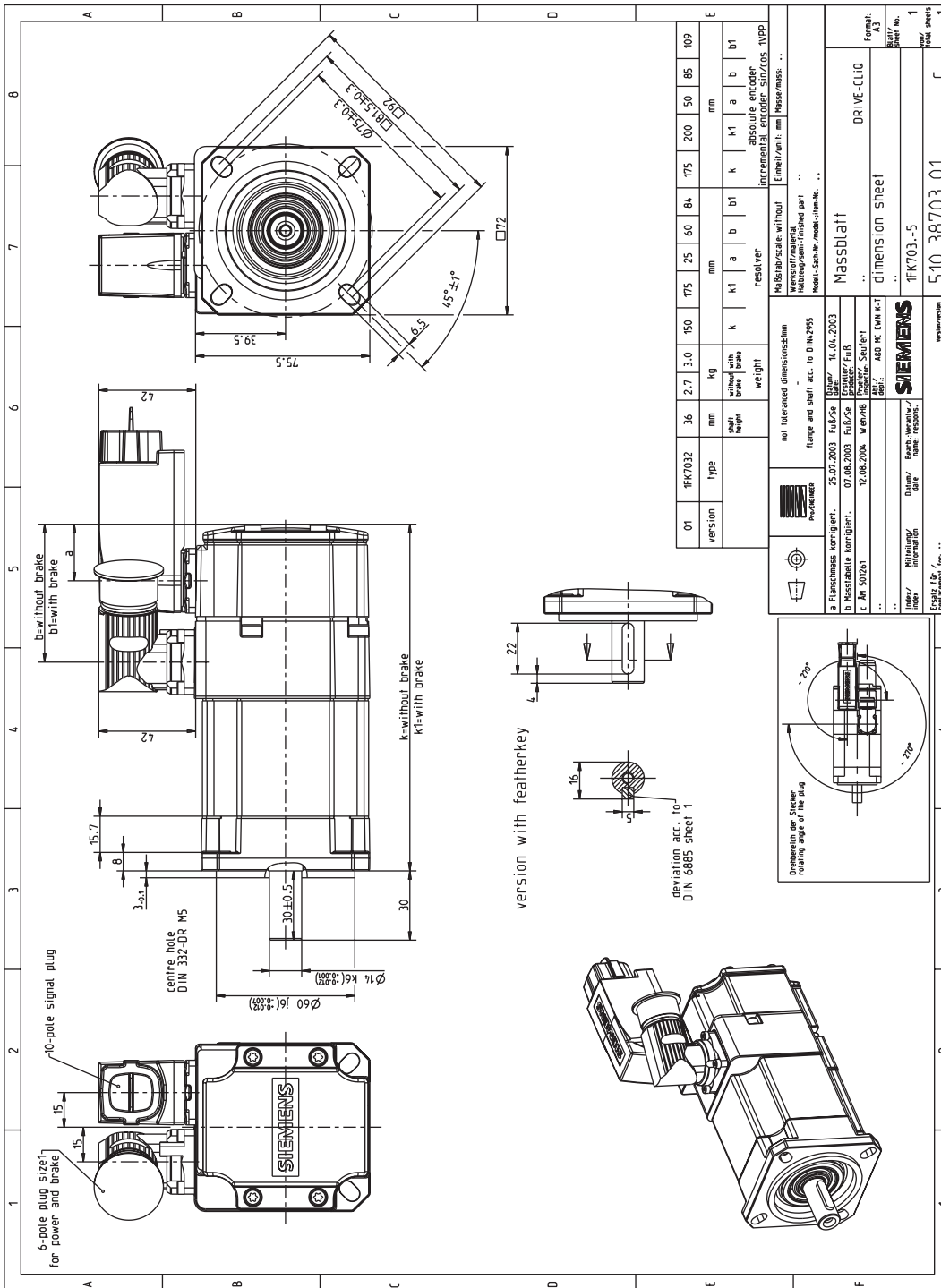

Figure 5-2 1FK703_-5A_DQ

5.2 1FK7 CT with DRIVE-CLiQ

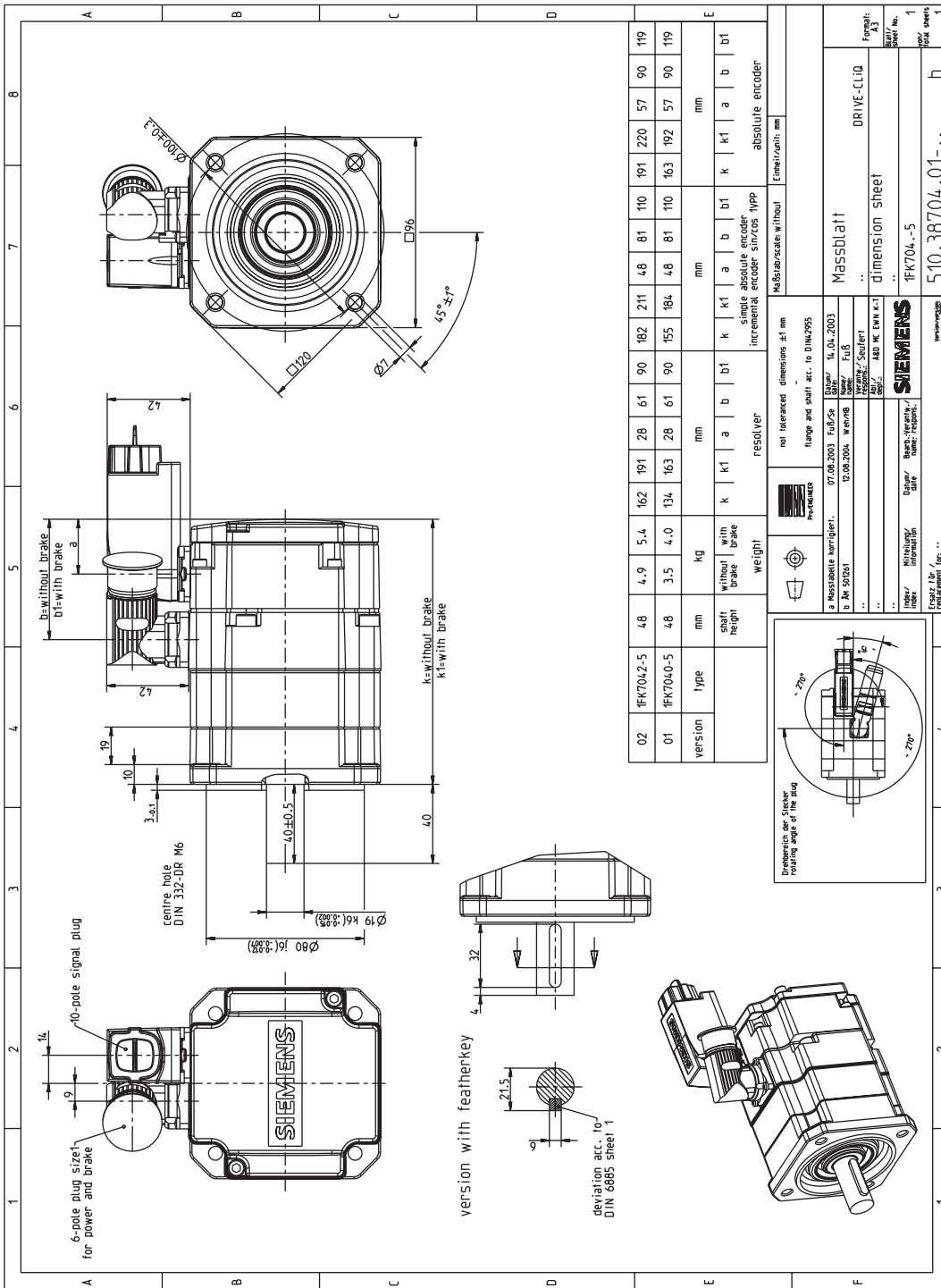

Figure 5-3 1FK704_-5A_DQ

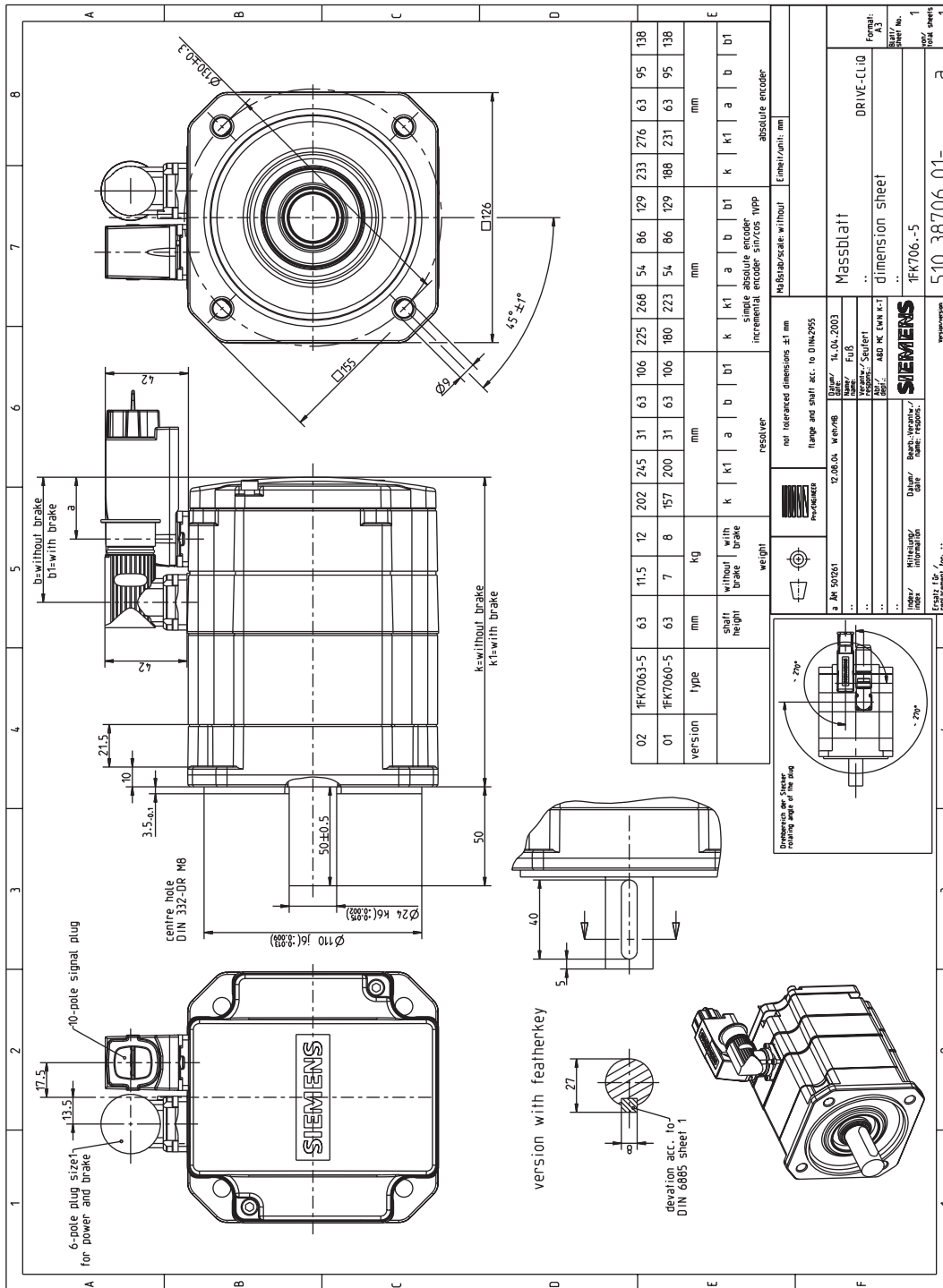

Figure 5-4 1FK706_-5A_DQ

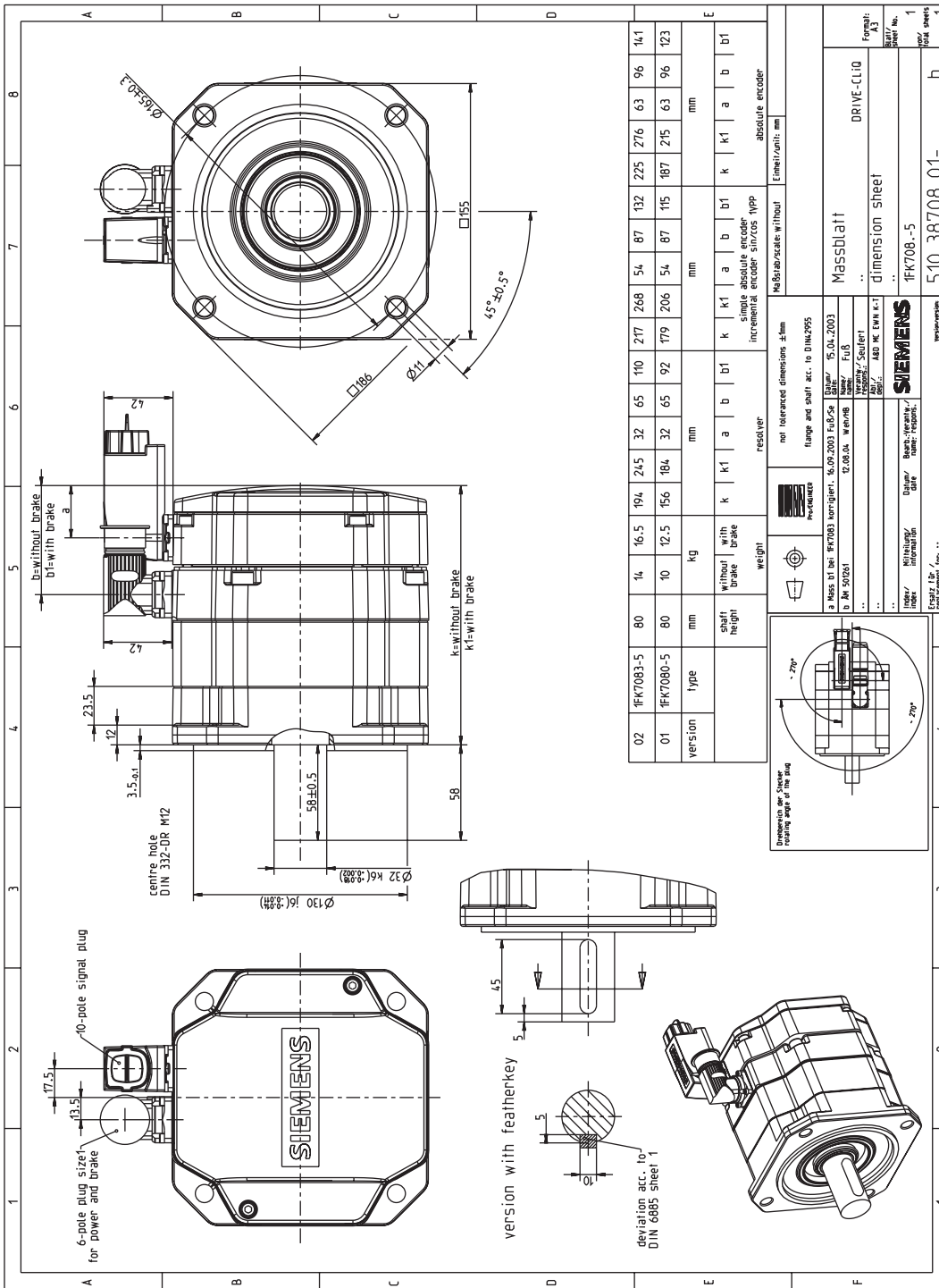

Figure 5-5 1FK708_-5A_DQ

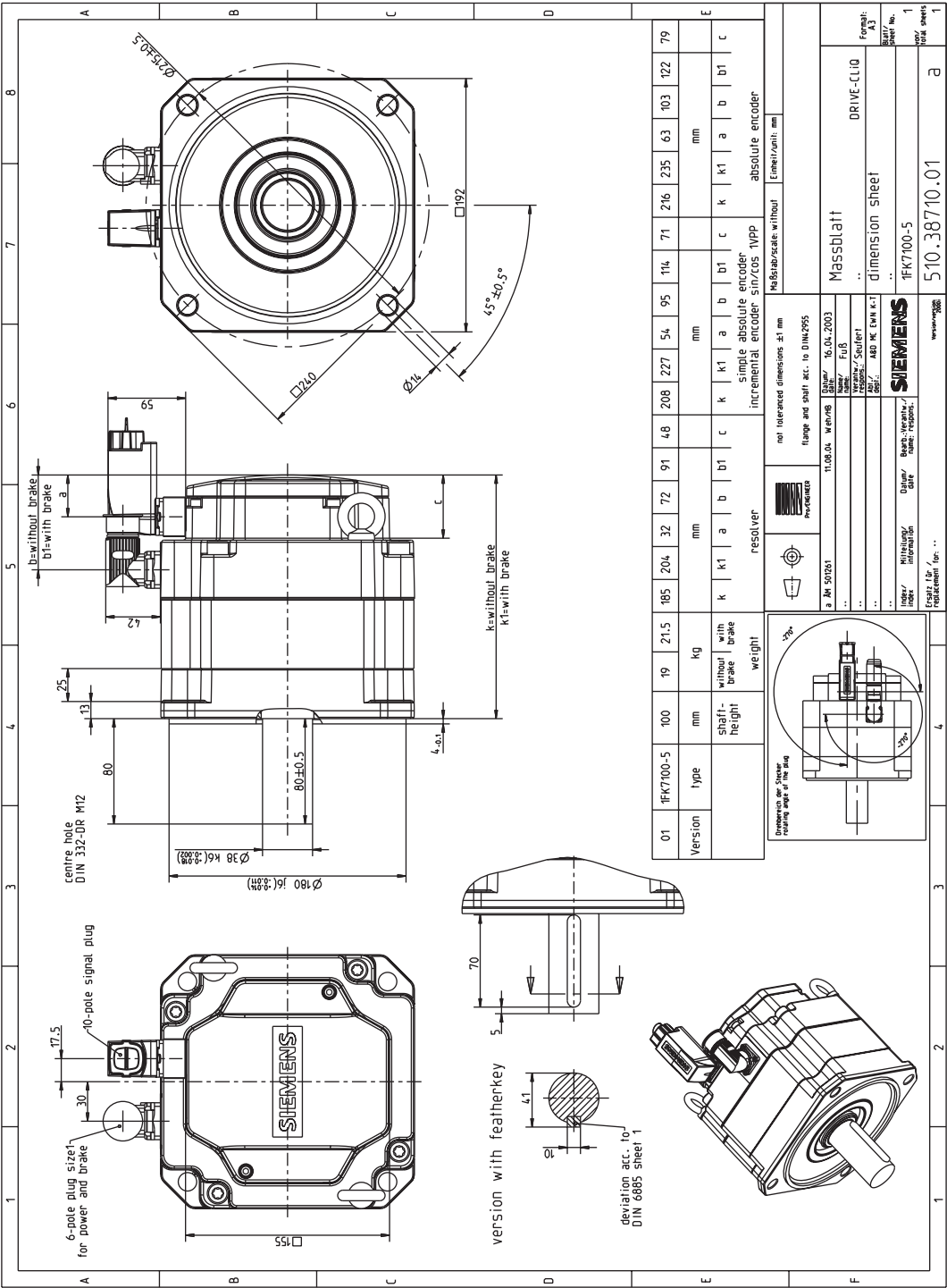

Figure 5-6 1FK7100-5A_DQ

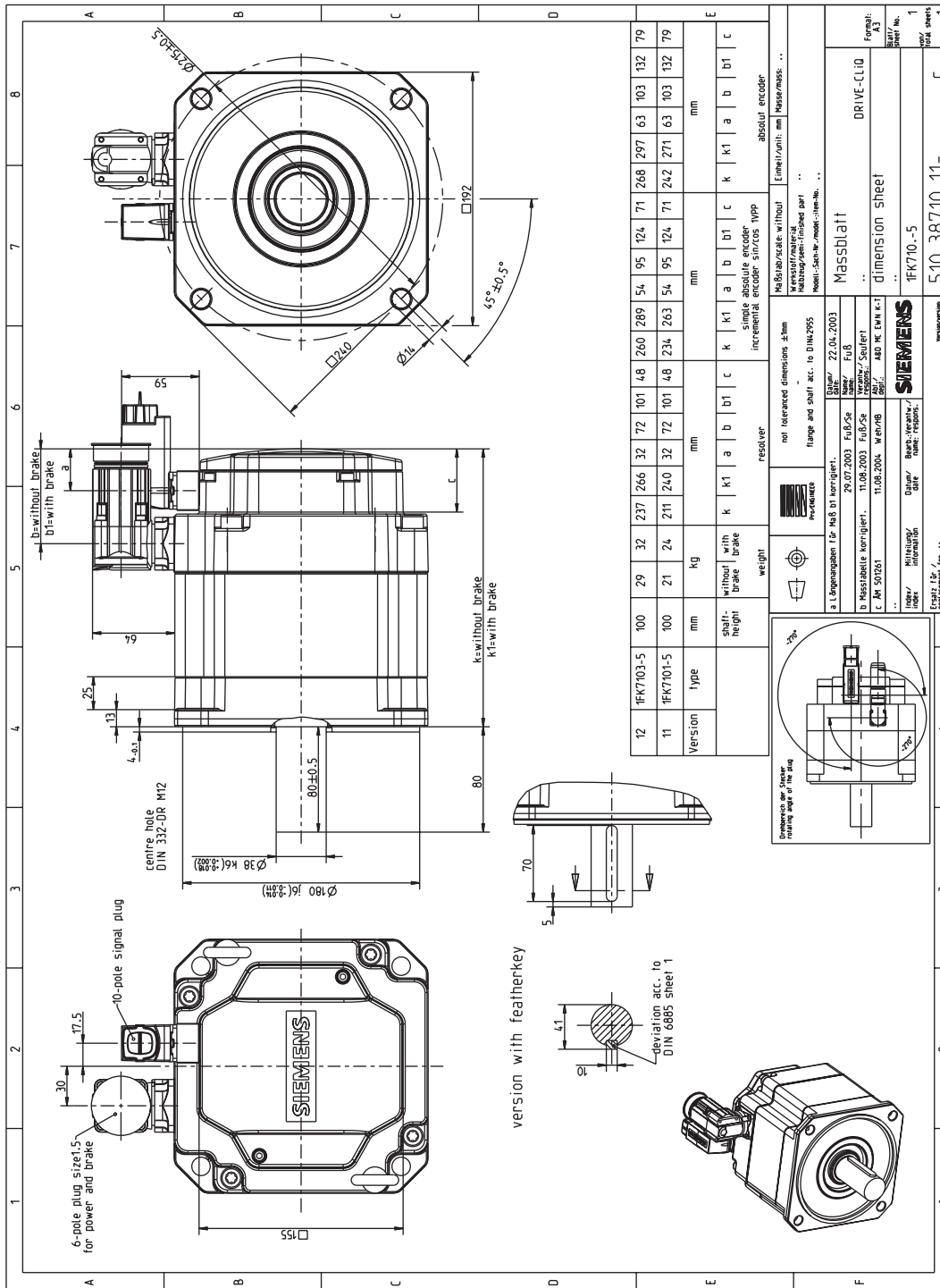

Figure 5-7 1FK7101_1FK7103_5A_DQ

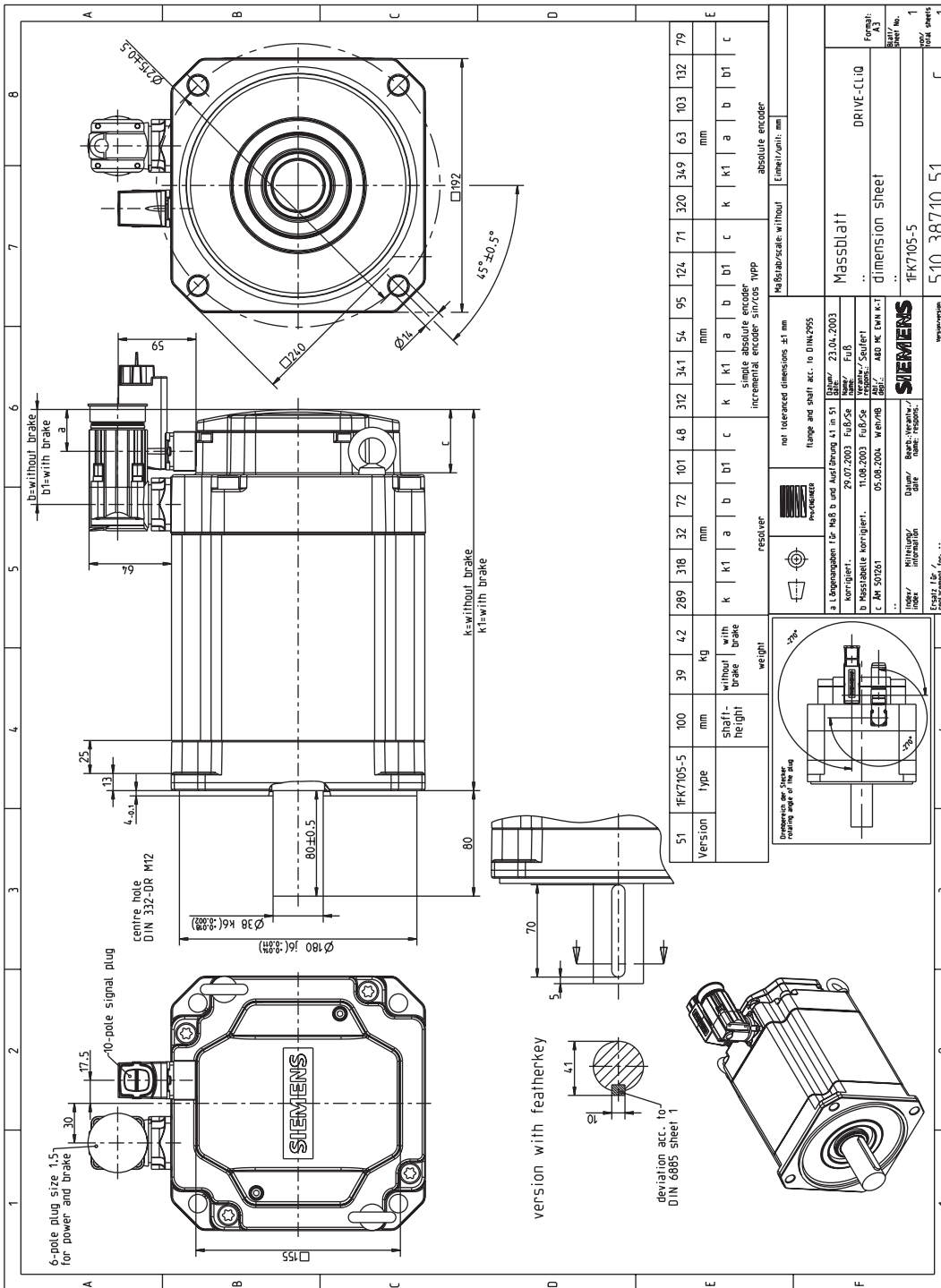

Figure 5-8 1FK7105-5A_DQ

5.3 1FK7 HD with DRIVE-CLiQ

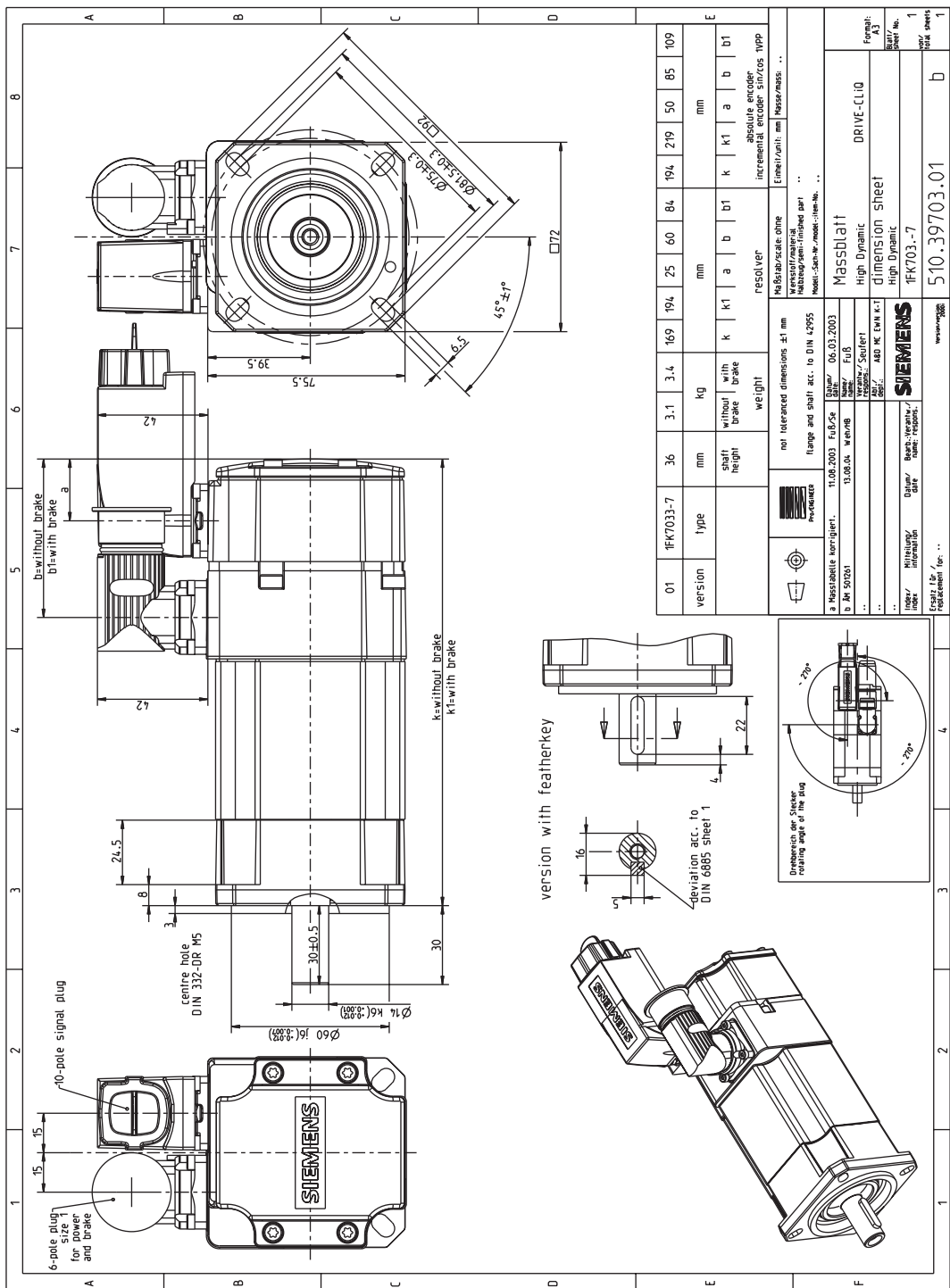

Figure 5-9 1FK703_7A_DQ

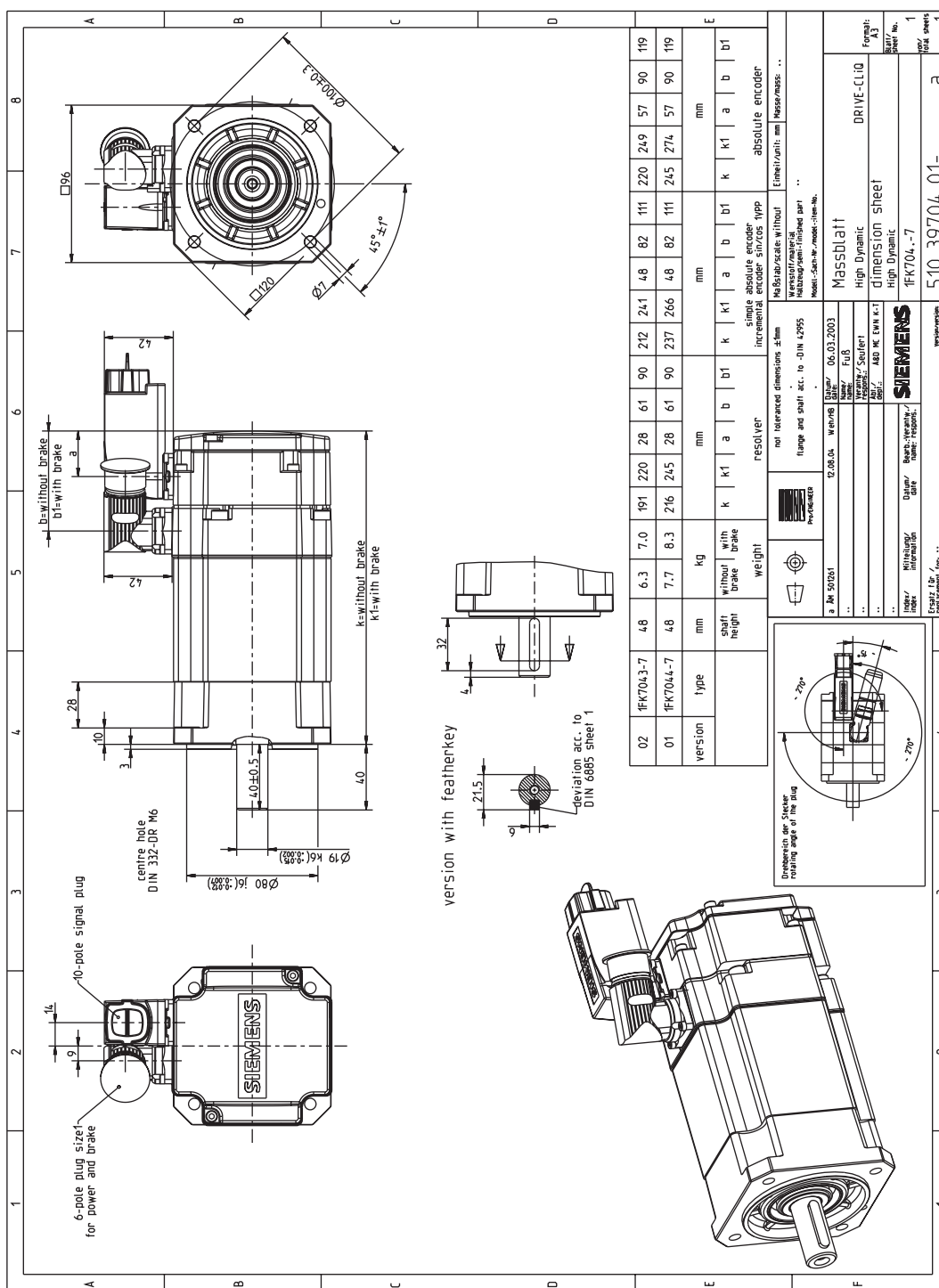

Figure 5-10 1FK704_-7A_DQ

5.3 1FK7 HD with DRIVE-CLiQ

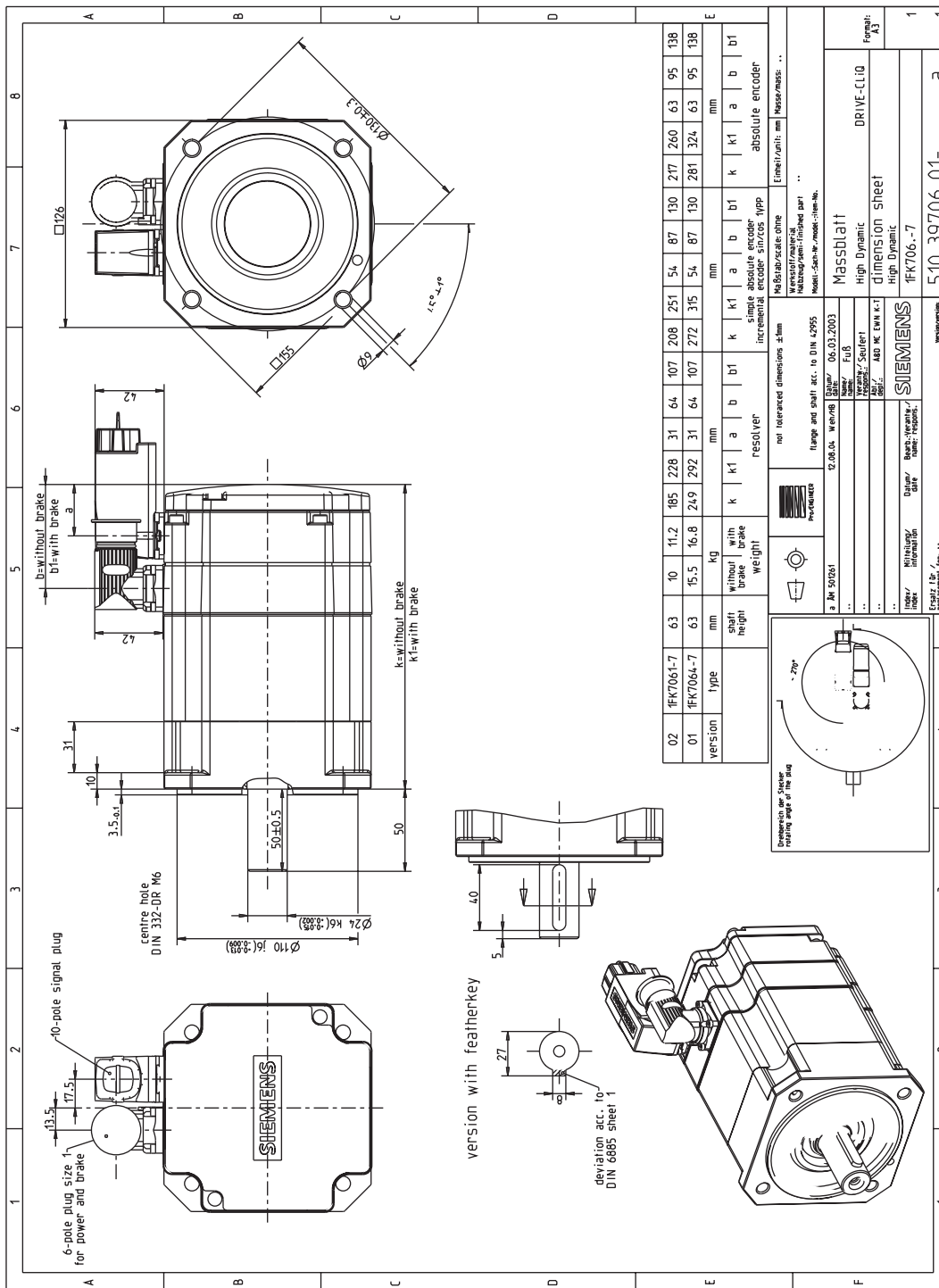

Figure 5-11 1FK706_-7A_DQ

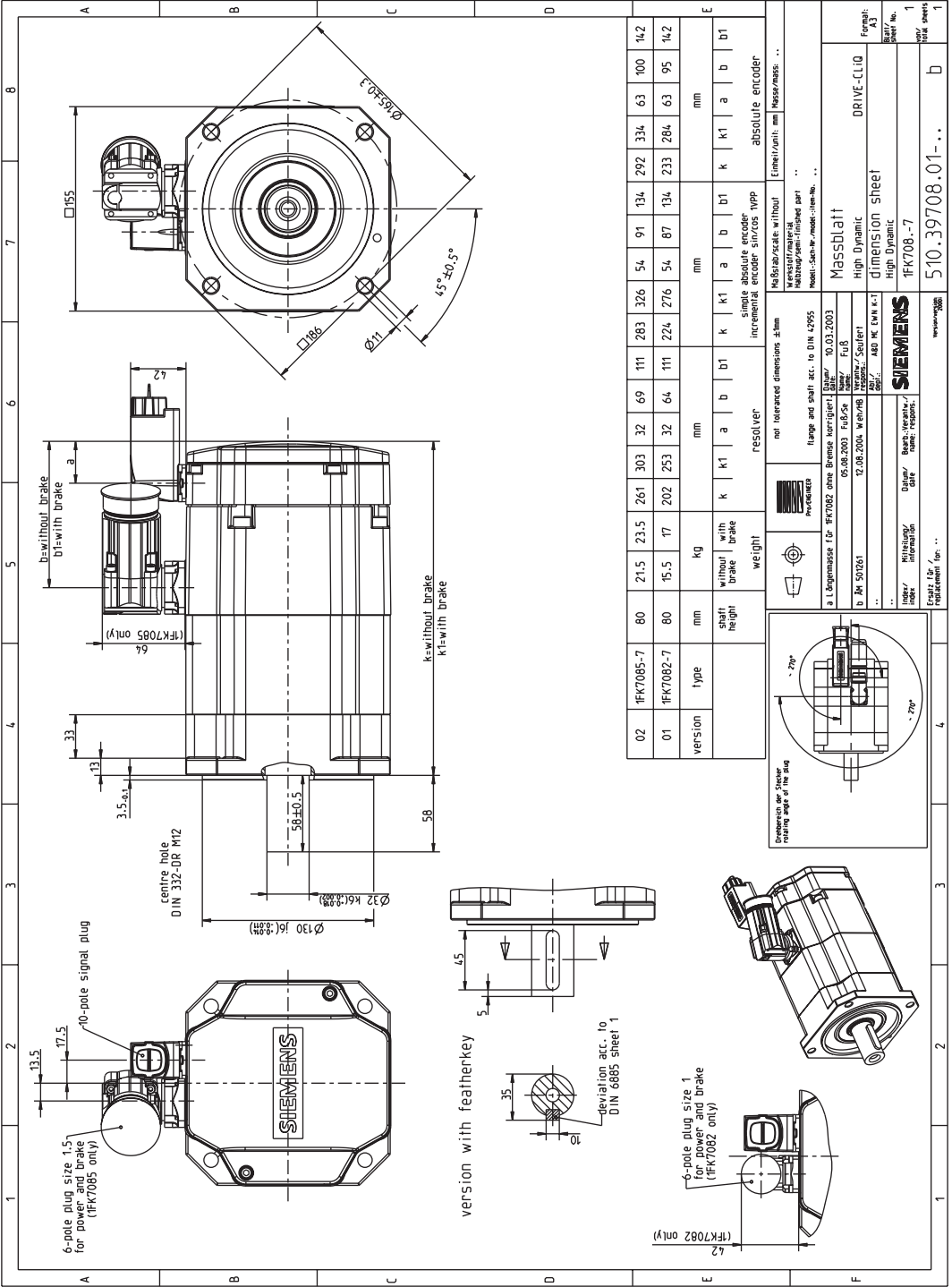

Figure 5-12 1FK7085-7A_DQ

5.4 1FK7 CT without DRIVE-CLiQ

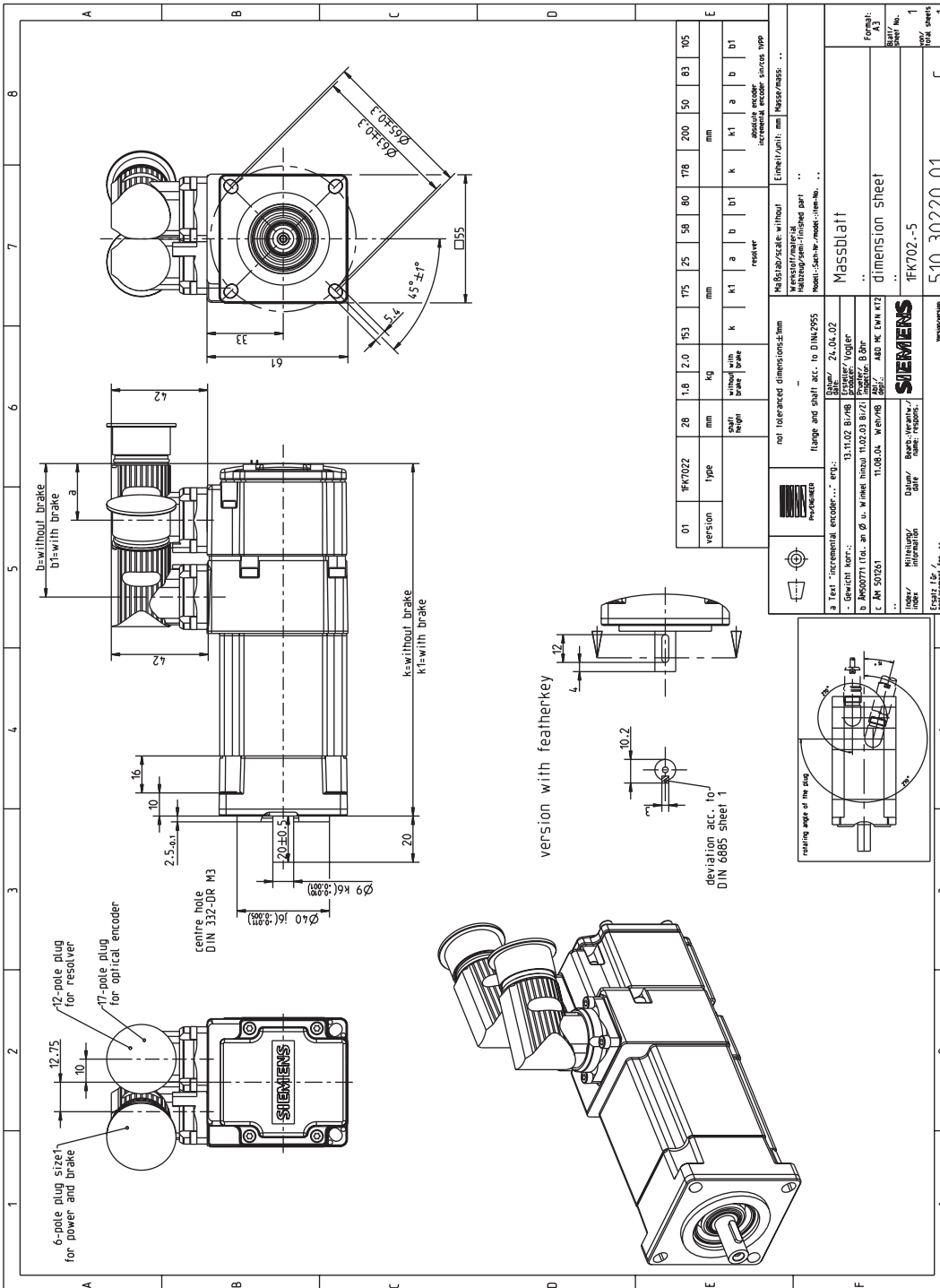

Figure 5-13 1FK702_5

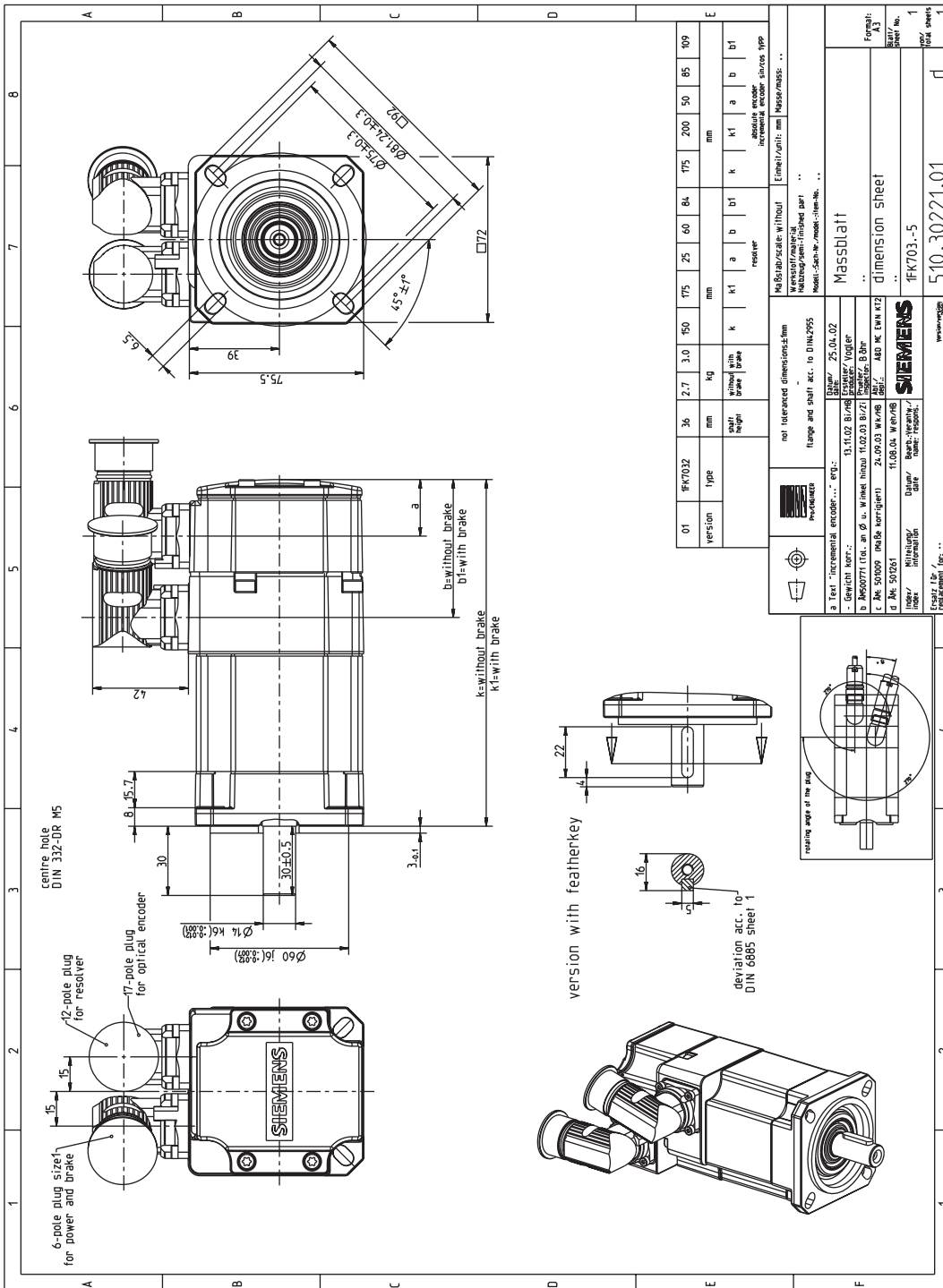

Figure 5-14 1FK703_-5

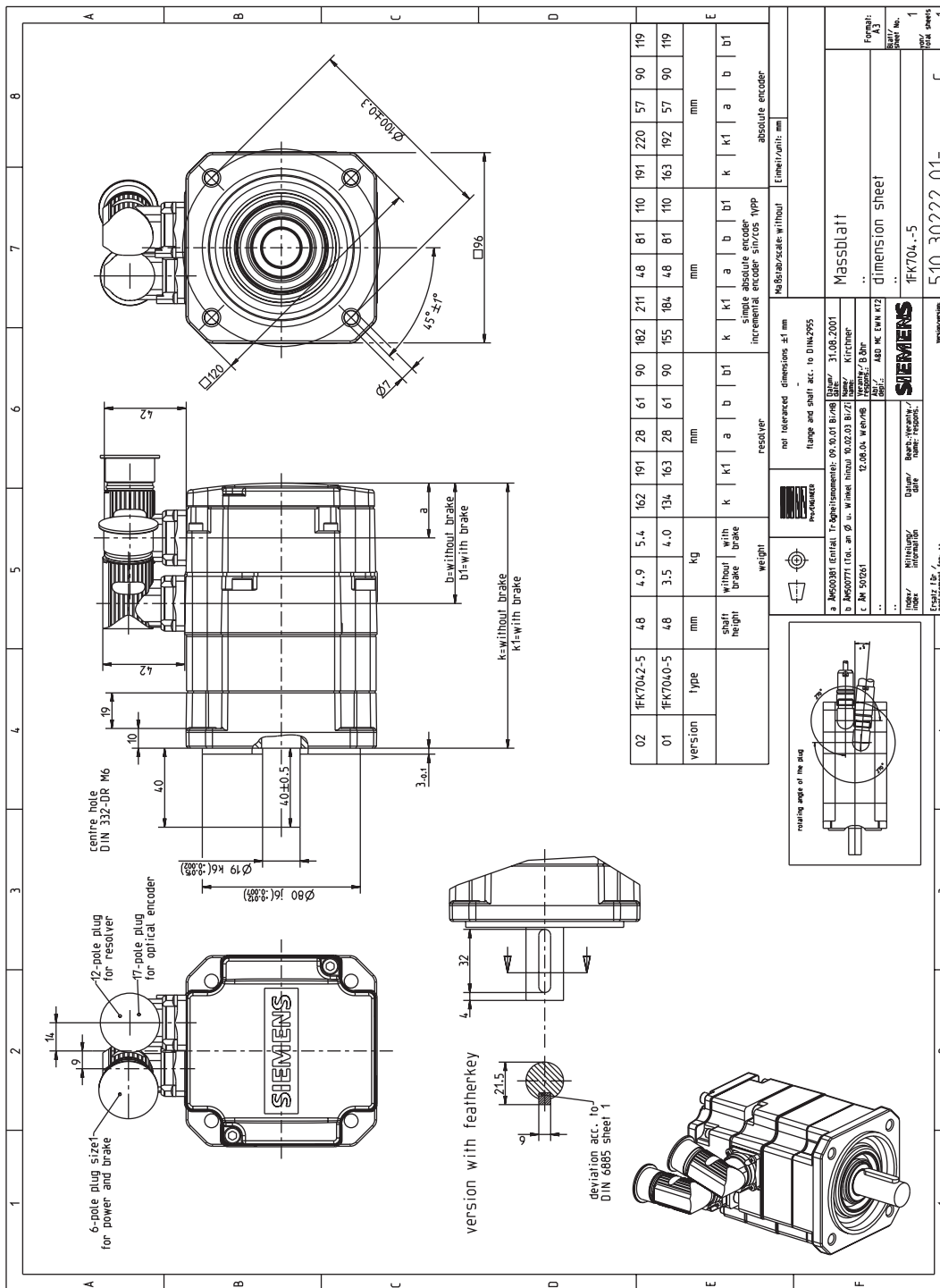

Figure 5-15 1FK704_-5, non-ventilated with angle connector, size 1

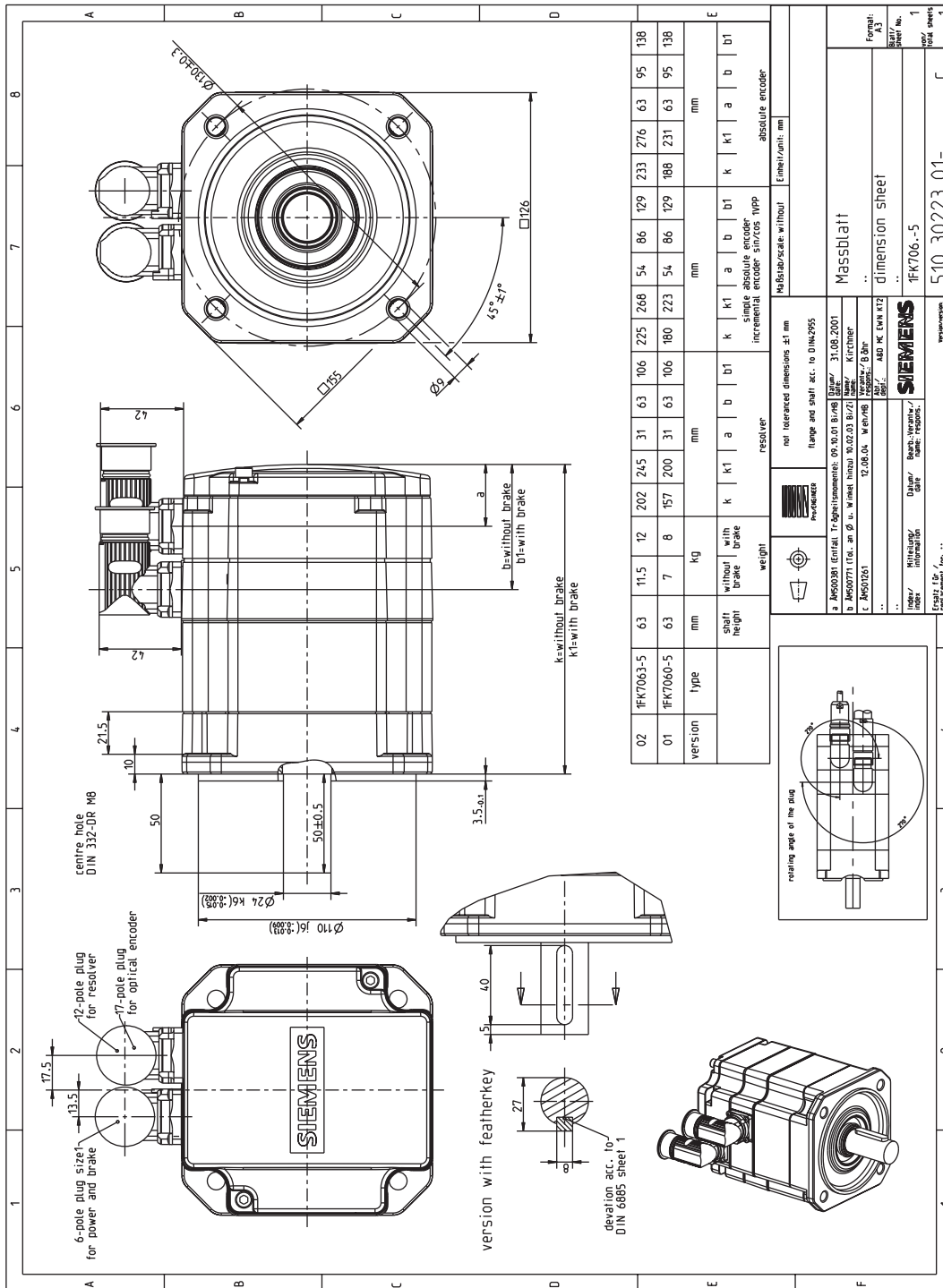

Figure 5-16 1FK706_-5, non-ventilated with angle connector, size 1

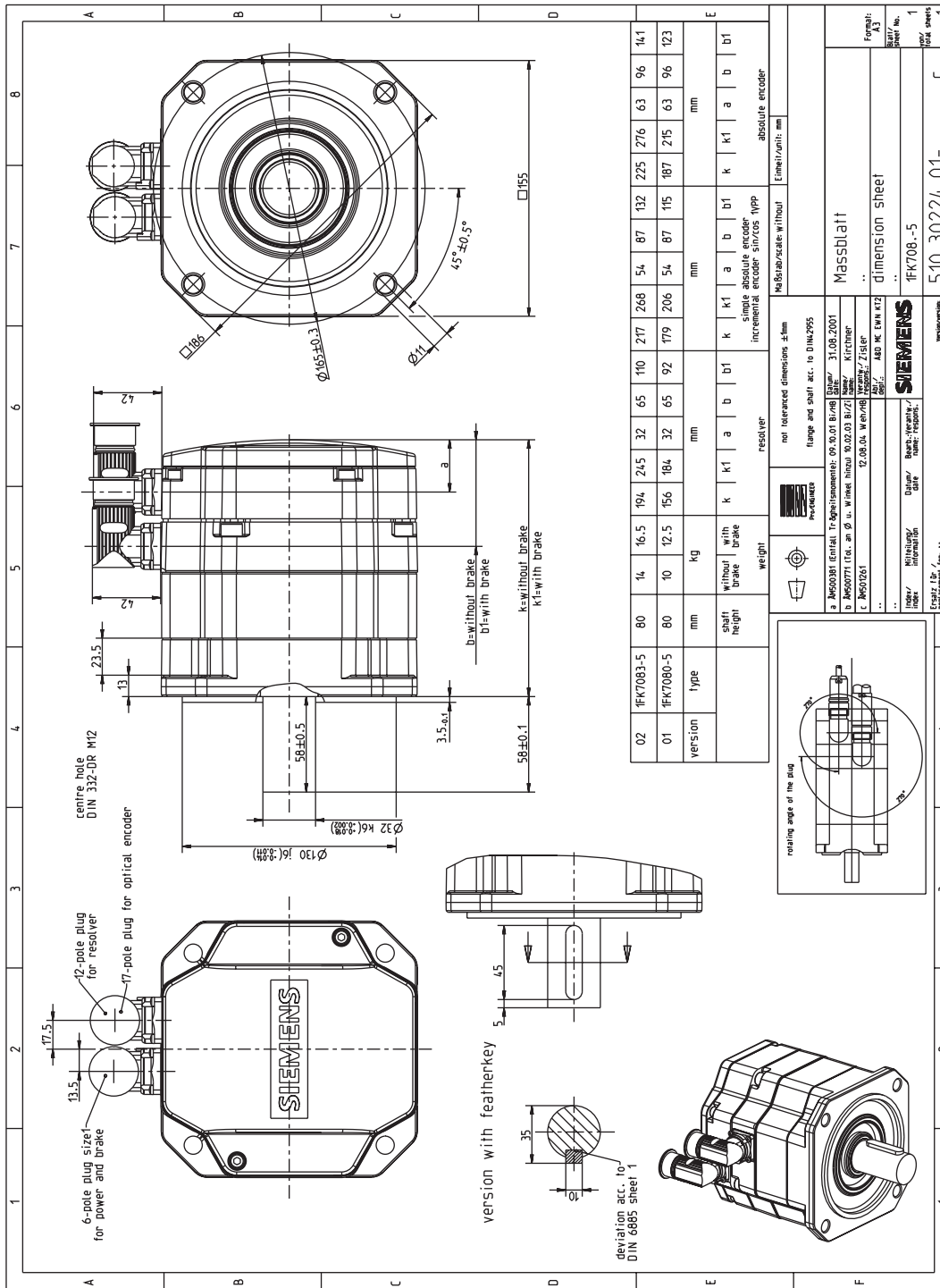

Figure 5-17 1FK708_-5, non-ventilated with angle connector, size 1

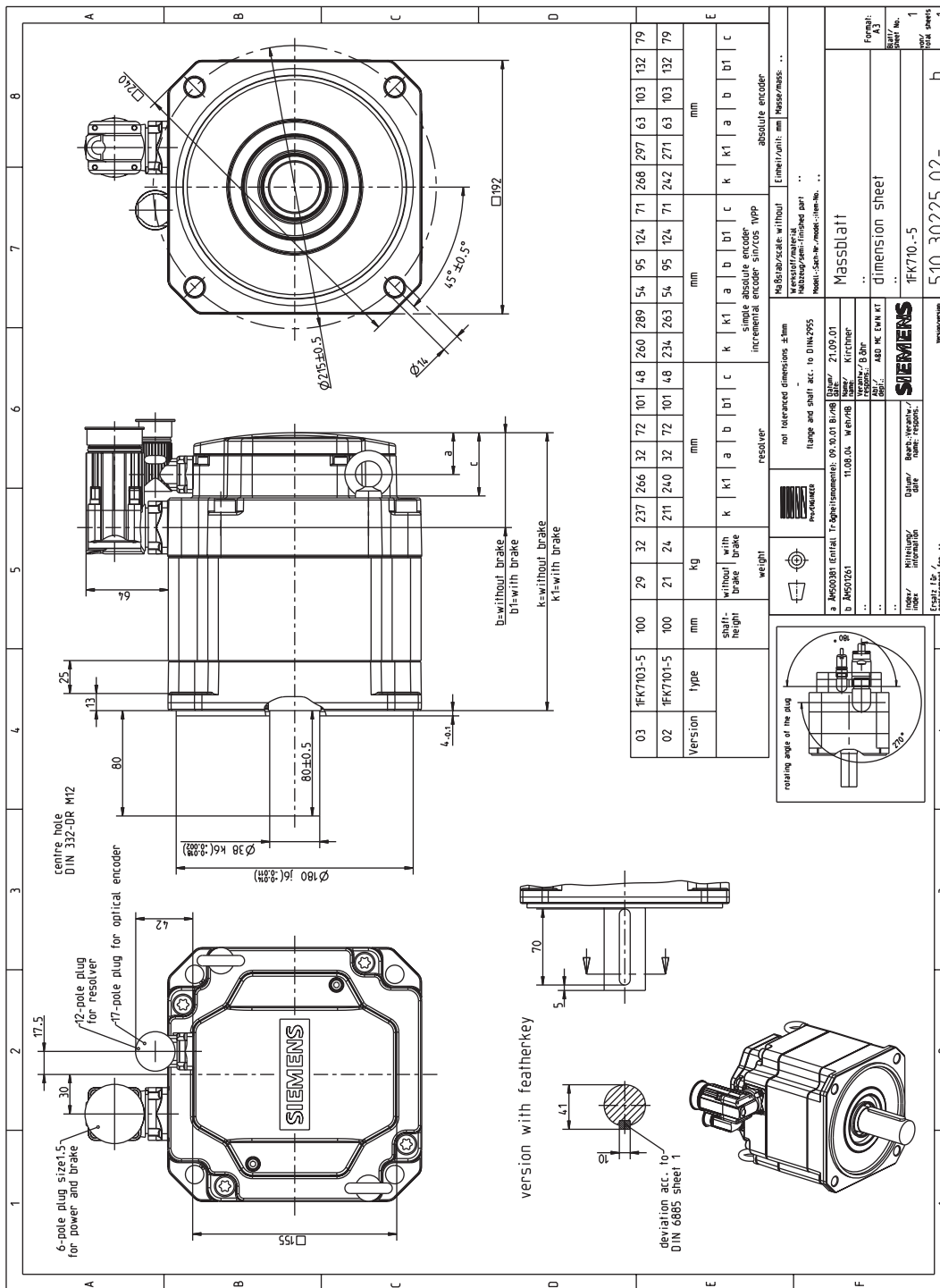

Figure 5-19 1FK710_5, non-ventilated with angle connector, size 1.5

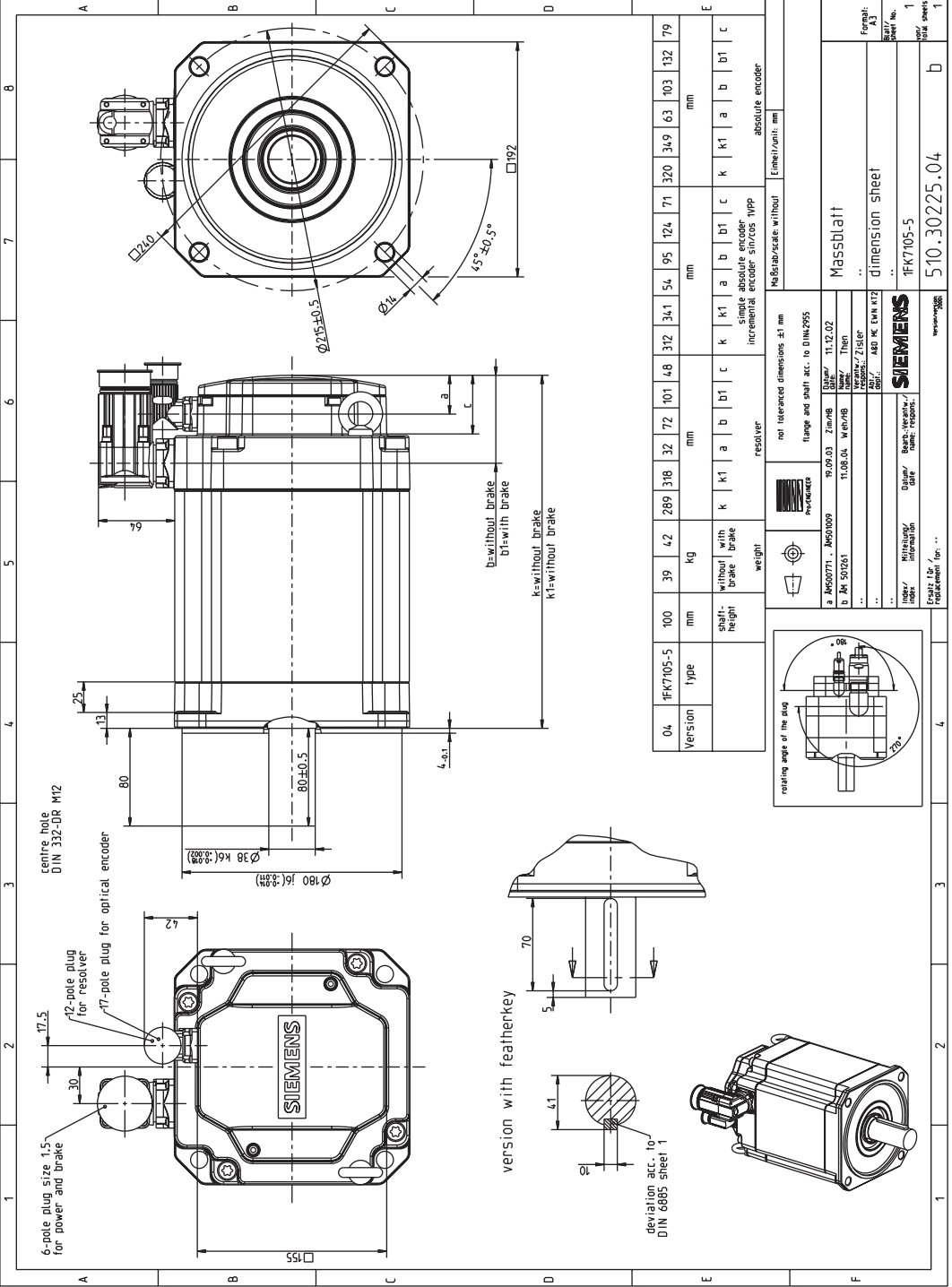

Figure 5-20 1FK7105-5

5.5 1FK7 HD without DRIVE-CLiQ

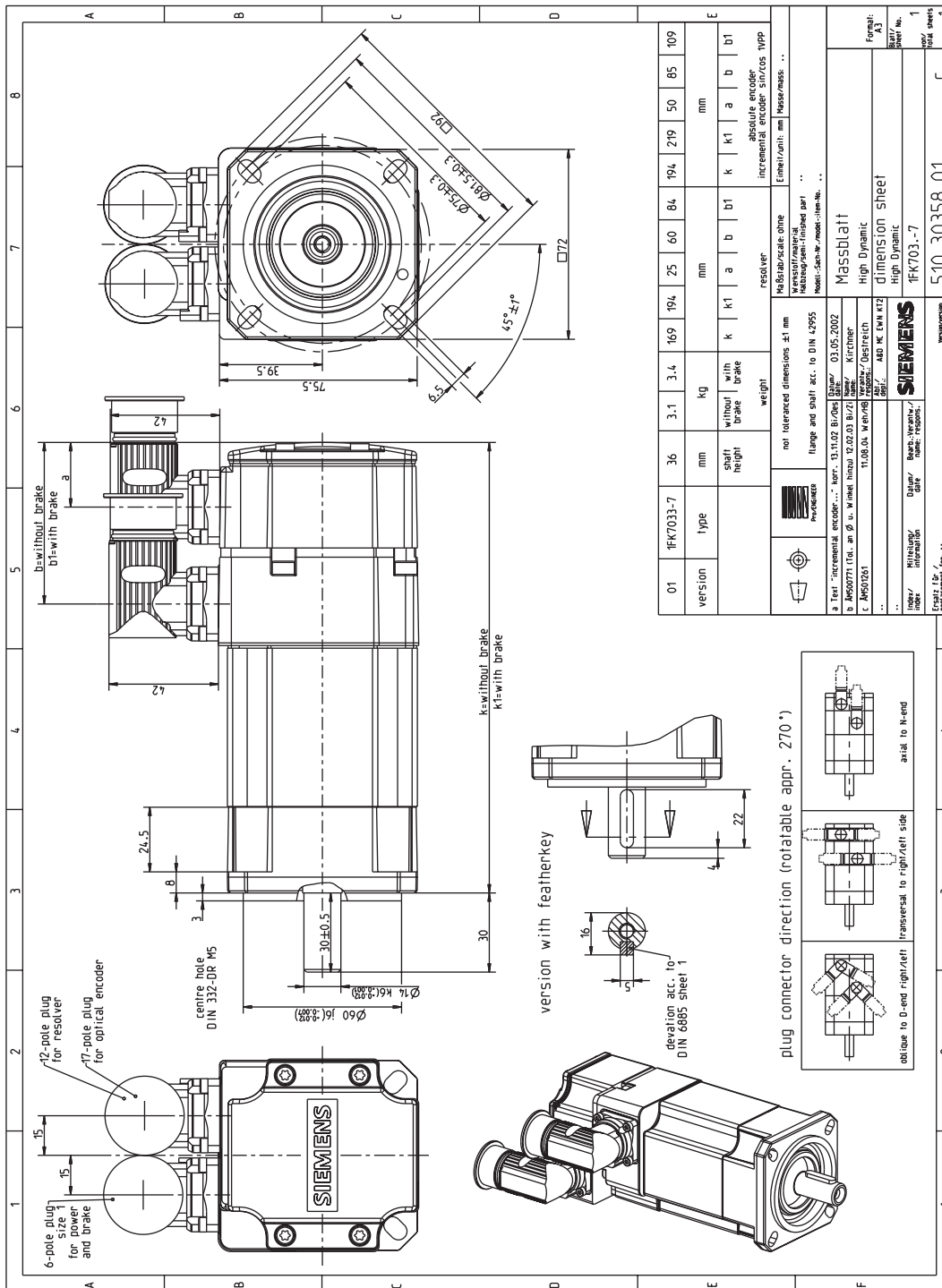

Figure 5-21 1FK703-7

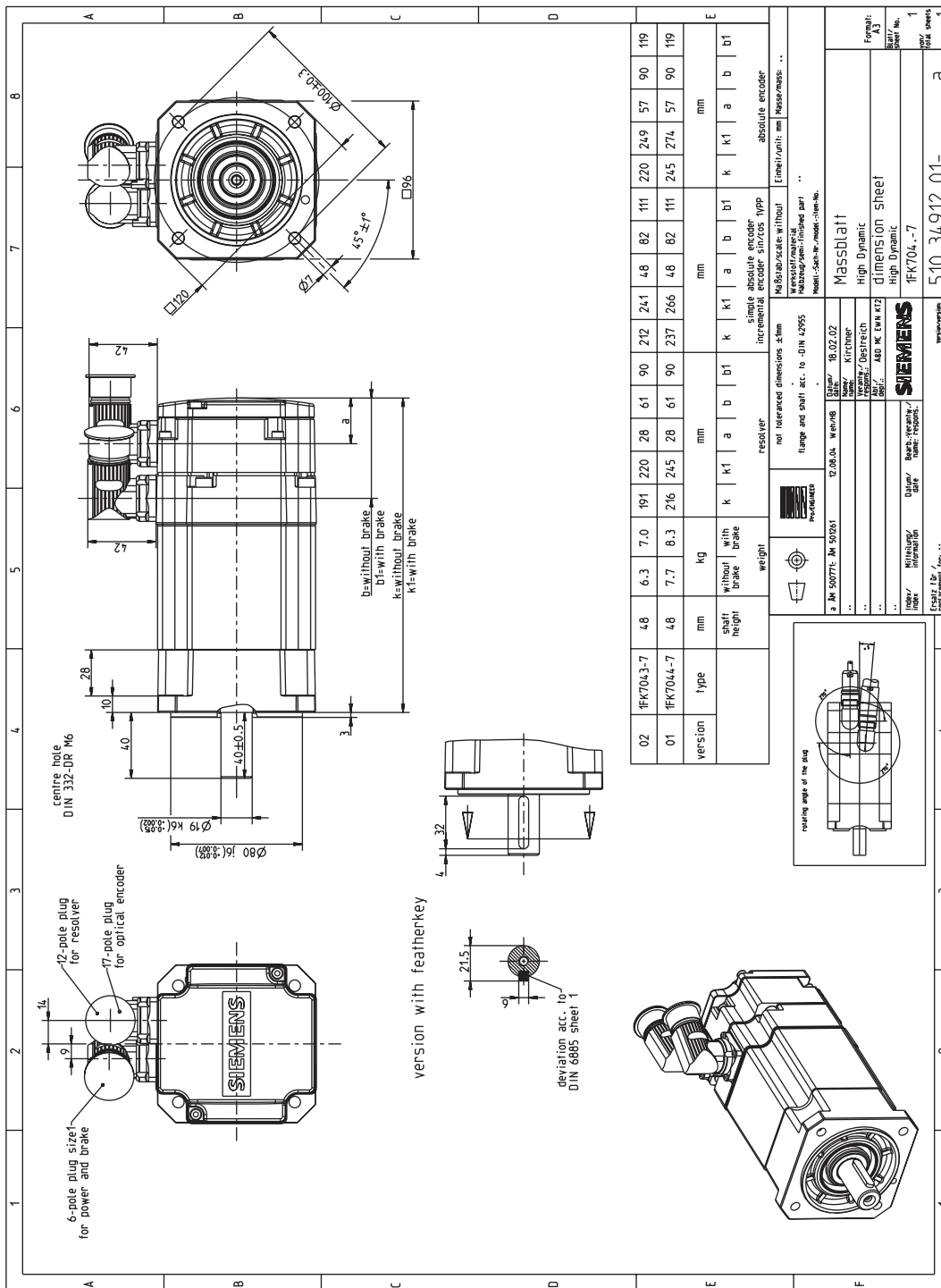

Figure 5-22 1FK704_-7

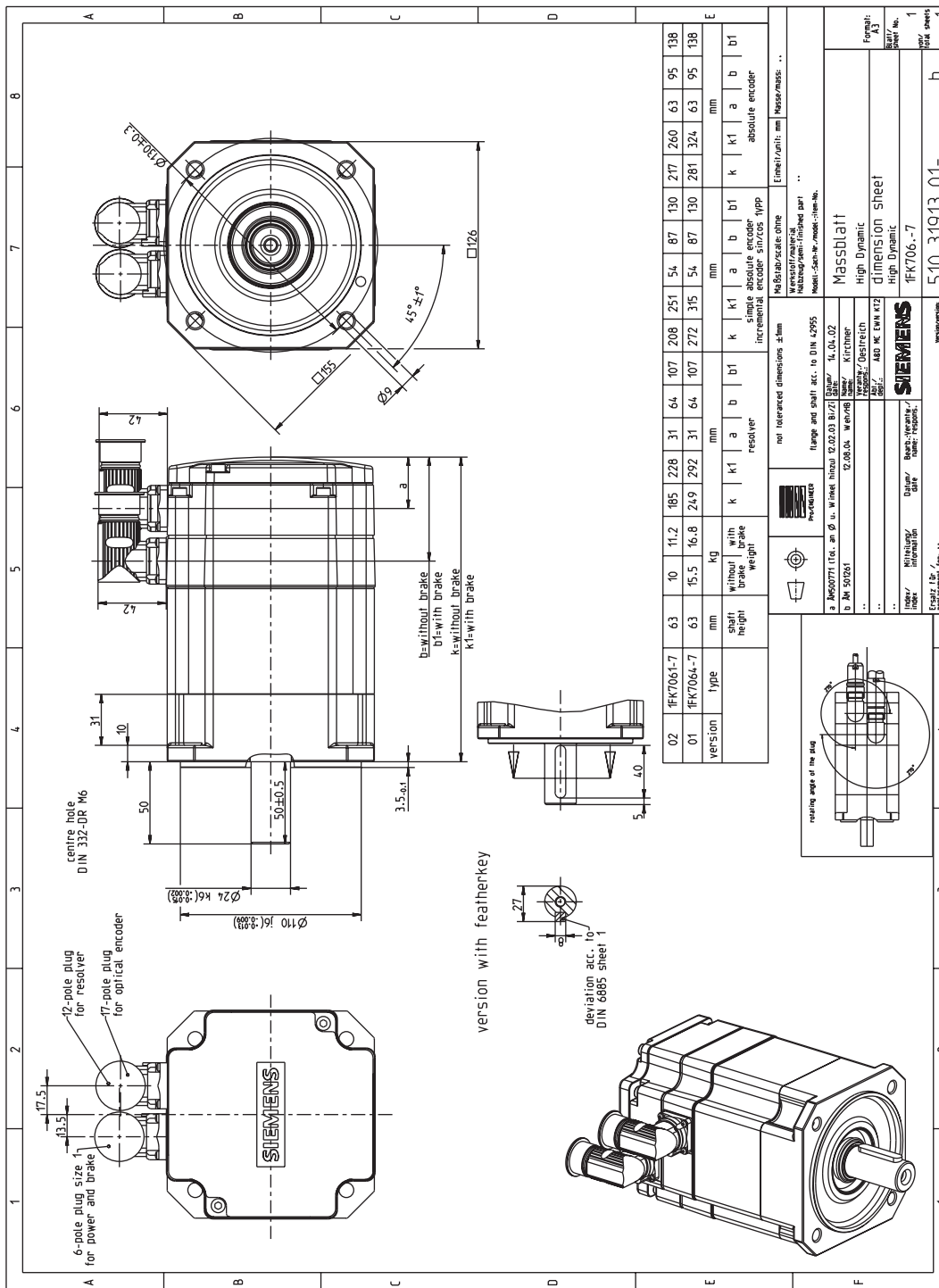

Figure 5-23 1FK7061-7

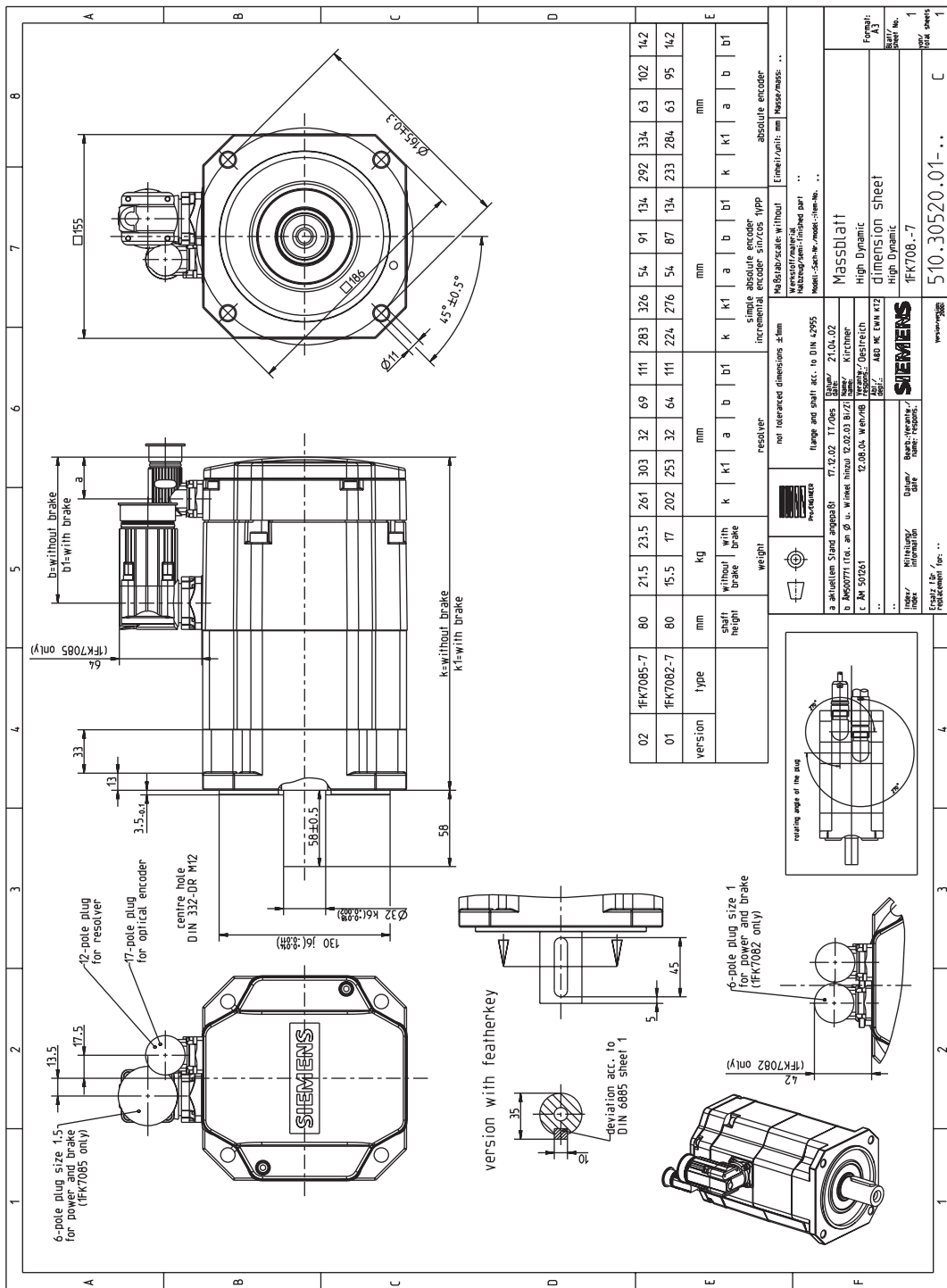

Figure 5-24 1FK708_-7

Appendix

A.1 References

An overview of publications that is updated monthly is provided in a number of languages in the Internet at:

<<http://www.siemens.com/motioncontrol>>
through "Support", "Technical Documentation", "Documentation Overview"

General Documentation

<i>/D 21.2/</i>	SINAMICS S120 Catalog SINAMICS S120 Servo Control Drive System
<i>/NC 60/</i>	SINUMERIK and SIMODRIVE Catalog Automation Systems for Machine Tools
<i>/DA65.3/</i>	SIMOVERT MASTERDRIVES Catalog Synchronous and Induction Motors for SIMOVERT MASTERDRIVES

Electronic Documentation

<i>/CD1/</i>	DOC ON CD The SINUMERIK System (includes all SINUMERIK 840D/810D and SIMODRIVE 611D)
<i>/CD2/</i>	DOC ON CD The SINAMICS System

Manufacturer/Service Documentation

/PJAL/	Configuration Manual, Synchronous Motors SINAMICS S120, SIMODRIVE 611, SIMOVERT MASTERDRIVES Synchronous Motors General Section
/PFK7S/	Configuration Manual, Synchronous Motors SINAMICS S120 1FK7 Synchronous Motors
/PFT6S/	Configuration Manual, Synchronous Motors SINAMICS S120 1FT6 Synchronous Motors
/PMH2/	Installation Manual, Hollow Shaft Measuring System SINAMICS S120, SIMODRIVE 611, SIMOVERT MASTERDRIVES, SIMAG H2 Hollow-Shaft Measuring System
/PFK7/	Configuration Manual, Synchronous Motors SIMODRIVE 611, SIMOVERT MASTERDRIVES 1FK7 Synchronous Motors
/PFT6/	Configuration Manual, Synchronous Motors SIMODRIVE 611, SIMOVERT MASTERDRIVES 1FT6 Synchronous Motors
/PFK6/	Configuration Manual, Synchronous Motors SIMODRIVE 611, SIMOVERT MASTERDRIVES 1FK6 Synchronous Motors
/PFS6/	Configuration Manual, Synchronous Motors SIMOVERT MASTERDRIVES 1FS6 Synchronous Motors, Explosion-Protected
/PFU/	Configuration Manual, Synchronous Motors SINAMICS S120, SIMOVERT MASTERDRIVES, MICROMASTER SIEMOSYN Synchronous Motors 1FU8

/ASAL/	Configuration Manual, Induction Motors SIMODRIVE 611, SIMOVERT MASTERDRIVES Induction Motors General Section
/APH2/	Configuration Manual, Induction Motors SIMODRIVE 611 1PH2 Induction Motors
/APH4/	Configuration Manual, Induction Motors SIMODRIVE 611 1PH4 Induction Motors
/APH7S/	Configuration Manual, Induction Motors SIMODRIVE 611 1PH7 Induction Motors
/PPM/	Configuration Manual, Hollow Shaft Motors SIMODRIVE 611 Hollow Shaft Motors for Main Spindle Drives 1PM6 and 1PM4
/PJFE/	Configuration Manual, Synchronous Build-in Motors SIMODRIVE 611 Synchronous Motors for Main Spindle Drives 1FE1 Synchronous Build-in Motors
/PJTM/	Configuration Manual, Build-in Torque Motors SIMODRIVE 611 Build-in Torque Motors 1FW6
/PJLM/	Configuration Manual, Linear Motors SIMODRIVE 611 Linear Motors 1FN1 and 1FN3

/PMS/	Configuration Manual, ECO Motor Spindle SIMODRIVE 611 ECO Motor Spindle 2SP1
/APL6/	Configuration Manual, Induction Motors SIMOVERT MASTERDRIVES Induction Motors 1PL6
/APH7M/	Configuration Manual, Induction Motors SIMOVERT MASTERDRIVES VC/MC Induction Motors 1PH7
/PKTM/	Configuration Manual, Complete Torque Motors SIMOVERT MASTERDRIVES Complete Torque Motors 1FW3

Index

1

1FK7 Compact, 1-4

A

Absolute value encoder, 4-8
Armature short-circuit braking, 1-8
Axial force stressing, 3-44

B

Brake resistors, 1-8

C

Cantilever force stressing, 3-40
Characteristics, 3-1
Coupling output, 1-10

D

Danger and warning information, iv
Dimension drawings, 5-1

E

Encoders, 4-3
ESDS instructions, vi

G

Gearbox, 4-13

H

Holding brake, 4-12
Holding torque, 4-12
Hotline, iii

I

Incremental encoders, 4-5, 4-9
Interfaces, 2-1

O

Order designation
1FK7 High Dynamic, 1-6

R

Resistance characteristic, 4-2
Resistor braking, 1-8
Resolvers, 4-10

S

Speed-torque diagrams
1FK7 CT, 3-2, 3-4
1FK7 HD, 3-26
Standard engineering, 1-1

T

Technical data
1FK7 Compact, 1-4
1FK7 High Dynamic, 1-6
1FK7022, 3-2, 3-4, 3-27
1FK7033, 3-26
1FK7040, 3-6
1FK7042, 3-8
1FK7043, 3-28
1FK7044, 3-30
1FK7060, 3-10
1FK7061, 3-32
1FK7063, 3-12
1FK7064, 3-34
1FK7080, 3-14
1FK7082, 3-36
1FK7083, 3-16
1FK7085, 3-38

1FK7100, 3-18
1FK7101, 3-20
1FK7103, 3-22
1FK7105, 3-24
Technical features and versions, 1-2
Temperature sensor, KTY 84, 4-1
Thermal motor protection, 4-1

To
 SIEMENS AG
 A&D MC BMS
 Postfach 3180
 D-91050 Erlangen
 Tel.: +49 (0) 180 / 5050 - 222 (Service Support)
 Fax: +49 (0) 9131 / 98 - 2176 (Documentation)
 email: motioncontrol.docu@erlf.siemens.de

From	
Name _____	
Company/Department _____	
Address _____	
Postal code: _____	Town: _____
Telephone: _____	/
Telefax: _____	/

Suggestions
Corrections
For Publication/Manual: Synchronous Motors 1FK7
Manufacturer/Service Documentation
Configuration Manual
Order No.: 6SN1197-0AD16-0BP0
Edition: 12.2004
If you come across any printing errors in this document, please let us know using this form. We would also be grateful for any suggestions and recommendations for improvement.

Suggestions and/or corrections



Siemens AG
Automation & Drives
Motion Control Systems
Postfach 3180, D -91050 Erlangen
Germany

www.siemens.com/motioncontrol

© Siemens AG 2004
Subject to change without prior notice
Order No.: 6SN1197-0AD16-0BP0

Printed in the Federal Republic of Germany