

DeviceNet and CANopen expansion modules for MAC motors

The modular construction of JVL's MAC50-141 and MAC800 series of integrated MAC motors makes them particularly well suited for a large number of fieldbus applications. The Devicenet module and the CANopen module are described in this product data sheet. The series also includes a Profibus module. New modules are under development, including for example modules for USB, Ethernet, Bluetooth and Zigbee wireless communication.

The AC-servo motor, encoder, amplifier, positional controller and network module are all built into the motor. The only connections required are a supply voltage and the network cables. A double-supply facility is available in order to ensure that position and parameters are maintained intact for example during an emergency stop. Via Devicenet and CANopen it is possible to access all of the MAC motor's registers.

The Devicenet module (MAC00-FD4) and the CANopen module (MAC00-FC4) are supplied with M12 connectors (IP67) with watertight connection for use in harsh industrial environments.

Modules with other types of connector can be developed to suit customer requirements.

Both modules offer the following features:

- Position, torque, and velocity control
- 4 I/O for version with M12 con-



nectors. 6 inputs and 2 outputs for version with cable glands. All 24V PNP and with opto-couplers.

- I/O can be used for end-of-travel limits and high-speed start/stop
- Hardware and software adjustment of baud rate and address
- Galvanically insulated I/O and network connections
- A selection of standard commands are addressable.

Devicenet Module FD4

The MAC00-FD4 module for the integrated servo motors enables the MAC motors to be used on Devicenet. The device hhhh standard method for controlling position when motion control is used on Devicenet.

At no additional cost, the EDS files, function blocks and program examples for the most commonly used Devicenet PLC's from Omron and Allen Bradley/Rockwell can be downloaded from www.jvl.dk. The function blocks are fully documented so they can be readily adapted for use with other PLC types.

CANopen Module MAC00-FC4

The MAC00-FC4 module for the integrated servo motors enables the MAC motors to be used on a CANopen or CANbus network. See more on www.can-cia.org.

The CAN module features:

- CANbus/CANopen DS 301 V3.0
- CANopen DSP 402 V2.0
- Baud rates from 10 to 1000kbit



Devicenet

DeviceNet is a proven, stable network technology designed to meet the performance and reliability requirements of the industrial environment. DeviceNet uses CAN (Controller Area Network) for its data link layer, and CIP™ (Common Industrial Protocol) for the upper-layers of the network. DeviceNet is an open standard managed by ODVA (see www.odva.org) and accepted by international standards bodies around the world. DeviceNet is supported by vendors around the world





and is the most used network for Allen Bradley/Rockwell and Omron PLC. DeviceNet is a digital, multi-drop network that connects and serves as a communication network between industrial controllers and I/O devices. Each device and/or controller is a node on the network. DeviceNet is a producer-consumer network that supports multiple communication hierarchies and message prioritization. DeviceNet systems can be configured to operate in a master-slave or a distributed con-

trol architecture using peer-to-peer communication. DeviceNet systems offer a single point of connection for configuration and control by supporting both I/O and explicit messaging. DeviceNet also has the unique feature of having power on the network. This allows devices with limited power requirements to be powered directly from the network, reducing connection points and physical size.

Comparison Chart

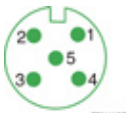
	DEVICENET	CANOPEN	CANBUS																																						
Nodes	Up to 64 Nodes	Up to 128	Extended frame up to 2 ²⁹																																						
Network Length	Selectable end-to-end network distance varies with speed <table border="1"> <tr> <td>125 Kbs</td> <td>500 m (1,640 ft)</td> </tr> <tr> <td>250 Kbs</td> <td>250 m (820 ft)</td> </tr> <tr> <td>500 Kbs</td> <td>100 m (328 ft)</td> </tr> </table>	125 Kbs	500 m (1,640 ft)	250 Kbs	250 m (820 ft)	500 Kbs	100 m (328 ft)	Selectable end-to-end network distance varies with speed: <table border="1"> <tr> <td>10Kbs</td> <td>5000m(16404ft.)</td> <td>125Kbs</td> <td>500m(1640ft.)</td> </tr> <tr> <td>20Kbs</td> <td>2500m(8202ft.)</td> <td>250Kbs</td> <td>250m(820ft.)</td> </tr> <tr> <td>50Kbs</td> <td>1000m(3280ft.)</td> <td>500Kbs</td> <td>100m(328ft)</td> </tr> <tr> <td>100Kbs</td> <td>700m(2996ft)</td> <td>1000Kbs</td> <td>30m(98.4ft.)</td> </tr> </table>	10Kbs	5000m(16404ft.)	125Kbs	500m(1640ft.)	20Kbs	2500m(8202ft.)	250Kbs	250m(820ft.)	50Kbs	1000m(3280ft.)	500Kbs	100m(328ft)	100Kbs	700m(2996ft)	1000Kbs	30m(98.4ft.)	Selectable end-to-end network distance varies with speed: <table border="1"> <tr> <td>10Kbs</td> <td>5000m(16404ft.)</td> <td>125Kbs</td> <td>500m(1640ft.)</td> </tr> <tr> <td>20Kbs</td> <td>2500m(8202ft.)</td> <td>250Kbs</td> <td>250m(820ft.)</td> </tr> <tr> <td>50Kbs</td> <td>1000m(3280ft.)</td> <td>500Kbs</td> <td>100m(328ft)</td> </tr> <tr> <td>100Kbs</td> <td>700m(2996ft)</td> <td>1000Kbs</td> <td>30m(98.4ft.)</td> </tr> </table>	10Kbs	5000m(16404ft.)	125Kbs	500m(1640ft.)	20Kbs	2500m(8202ft.)	250Kbs	250m(820ft.)	50Kbs	1000m(3280ft.)	500Kbs	100m(328ft)	100Kbs	700m(2996ft)	1000Kbs	30m(98.4ft.)
125 Kbs	500 m (1,640 ft)																																								
250 Kbs	250 m (820 ft)																																								
500 Kbs	100 m (328 ft)																																								
10Kbs	5000m(16404ft.)	125Kbs	500m(1640ft.)																																						
20Kbs	2500m(8202ft.)	250Kbs	250m(820ft.)																																						
50Kbs	1000m(3280ft.)	500Kbs	100m(328ft)																																						
100Kbs	700m(2996ft)	1000Kbs	30m(98.4ft.)																																						
10Kbs	5000m(16404ft.)	125Kbs	500m(1640ft.)																																						
20Kbs	2500m(8202ft.)	250Kbs	250m(820ft.)																																						
50Kbs	1000m(3280ft.)	500Kbs	100m(328ft)																																						
100Kbs	700m(2996ft)	1000Kbs	30m(98.4ft.)																																						
Data Packets	0-8 bytes	0-8 bytes	0-8 bytes																																						
Bus Topology	Linear (trunkline/dropline); power and signal on the same network cable	Linear (trunkline/dropline); power and signal on the same network cable	Linear (trunkline/dropline); power and signal on the same network cable																																						
Bus Addressing	Peer-to-Peer with Multi-Cast (one-to-many); Multi-Master and Master/Slave special case; polled or change-of-state (exception-based)	Master/Slave Producer/Consumer	None																																						

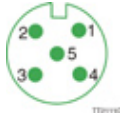
Motor Connector Description

		Connector	1	2	3	4	5	6	7	8
BUS1 (Bus in)	CANopen	M12 Male 5pin	CAN_SHLD	CAN_V+	CAN_GND	CAN_H	CAN_L			
	DeviceNet		Drain	V+	V-	CAN_H	CAN_L			
	Cable Color code		bare	red	black	white	blue			
BUS2 (Bus out)	CANopen	M12 Female 5pin	CAN_SHLD	CAN_V+	CAN_GND	CAN_H	CAN_L			
	DeviceNet		Drain	V+	V-	CAN_H	CANL			
	Cable Color code		bare	red	black	white	blue			
PWR (Power supply)	CANopen DeviceNet	M12 Male 5 pin	P+ (12-48VDC)	P+ (12-48VDC)	P- (GND)	CV Control voltage	P- (GND)			
	Cable Color code		Brown	White	Blue	Black	Grey			
I/O	CANopen DeviceNet	M12 Female 8 pin	IOC. PL or O1	Tx (RS232)	Rx (RS232)	GND (RS232)	IOA. AIN or O2	IOB. IN1 or O1	IO-	IOD. NL or O+
	Cable Color code		White	Brown	Green	Yellow	Grey	Pink		Red



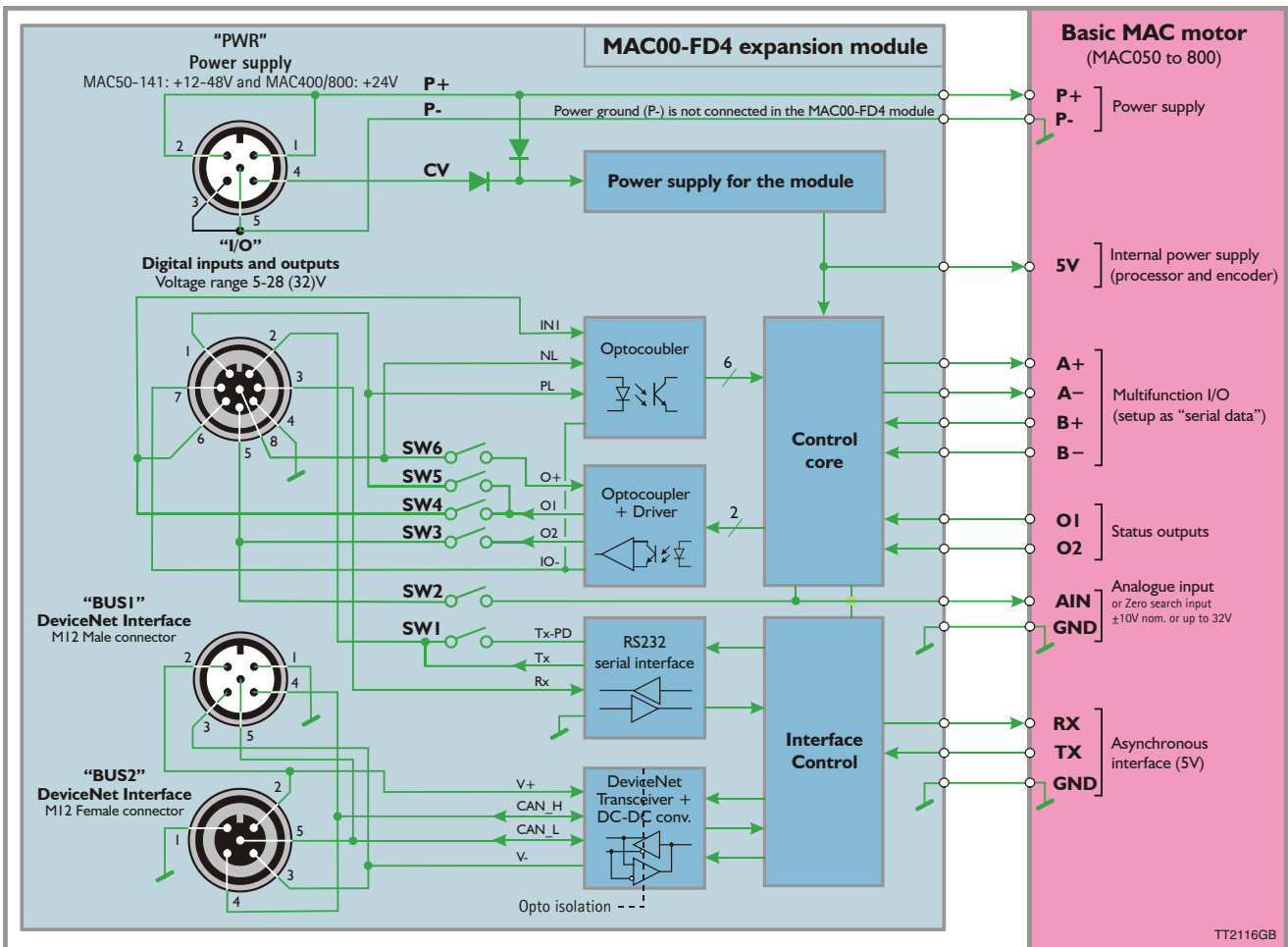

Block diagram of MAC00-FD4 with MAC motor

Easy start with sample code for Omron and Allen Bradley PLC

At no additional cost, the Expansion Module is supplied with EDS files, function blocks and program examples for the most commonly used DeviceNet PLC's from Omron (CJ1) and Allen Bradley platform (SLC500 and Logix). The function blocks are fully documented so they can be readily adapted for use with other PLC types.

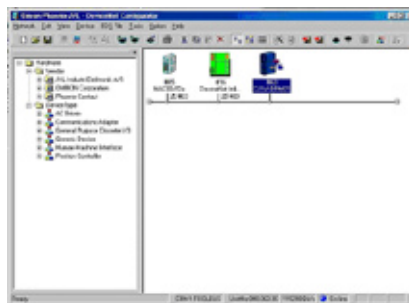

Easy installation with M12 connector

JVL MACmotor expansion board MAC00-FD4 and FC4 use a standard M12 connector with 5 and 8 pin. To ease installation there is one connector for BUS In and one for BUS Out.

I/O possibilities

The expansion boards are equipped with 6 inputs and 2 outputs, all galvanically isolated. Because of the limited number of pins in the M12 connector only some of the I/O's are available in the connector. With an internal dipswitch it is possible to select between O1, O2, AIN, INI, NL, PL, IO- and IO+ on 4 of the pins. Contact JVL if other configurations are required. For OEM use, a solution with cable glands or customer specified connector with all I/O's supported can be delivered.

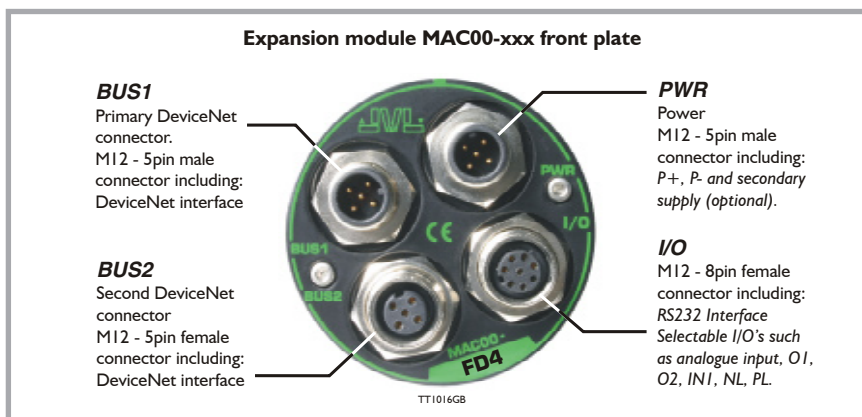



Cables and accessories

Cable and accessory	Description M12 IP67 (Standard cable with shield)	Connector	Type code	Picture
A	RS232 programming cable	I/O	RS232-M12-1-5-8	
B	Power cable	PWR	WI1000-M12F5AxxN	
C	IO cable	I/O	WI1000-M12F8AxxN	
D	BUS1 cable.	BUS1	WI1006-M12F55xxR	
E	BUS2 cable.	BUS2	WI1006-M12M55xxR	
F	Protection cap for M12 male	BUS1 or PWR	WI1000-M12MCAP1	
G	Protection cap for M12 female	BUS2 or I/O	WI1000-M12FCAP1	
H	Connector 5 pin female straight solder terminals	BUS1 or PWR	WI1020-M12F5SSC	
I	Connector 5 pin male straight solder terminals	BUS2	WI1020-M12M5SSC	

xx indicates cable length 05 or 20 meters (flying leads)

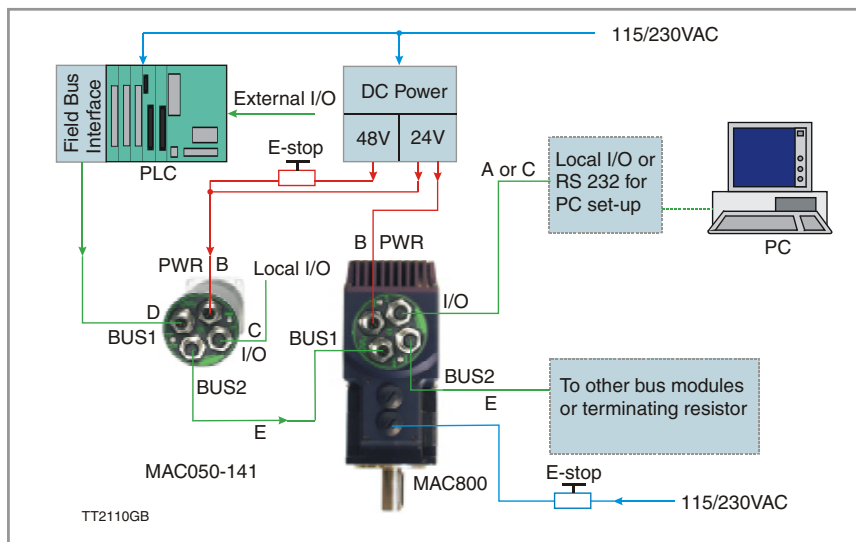

Two MAC motors in a network

Technical specifications

Absolute maximum rating

Description	Min	Typ	Max	Absolute Max	Unit
CV Current@ 24VDC*		250	400		mA
Voltage O+	10		30	32	VDC
Voltage P+	12		48	50	VDC
Control Voltage CV	12		48	50	VDC
Input IN1-4, NL,PL	4,5		28	32	VDC
Input Impedance		5,6			kOhms
Input current @24V		4,3			mA
Analoque input **	-10		10	32	VDC
Output O1, O2	0		30	32	VDC
Output current O1,O2			25		mA

* Only expansion module. Remember to add the current for the basic motor

** Resolution 11bit+sign for MAC800 and 9bit+sign for MAC050-MAC141

CANopen Features

Features	Contacts
NMT	Slave
Error control	Node guarding, Heartbeat
Node ID	Hardware switch, Software switch
No. of PDO	10 Rx, 11Tx
PDO modes	Event-triggered, Time-triggered, Remotely-requested, Sync (cyclic), Sync (acyclic)
PDO linking	Yes
PDO mapping	Static
No. of SDO	1 Server, 1 Client
Emergency message	Yes
Supported application layer	CiA DS 301 V 3.0 CiA DS 301 V 4.02
Supported frameworks	None
Supported profiles	CiA DSP 402 V 2.0

Protection

The Modules are supplied with M12 connectors (IP67) with watertight connection for use in industrial environments. Modules with other types of connector can be developed to suit customer requirements.



JVL Industri Elektronik A/S
 Blokken 42
 DK-3460 Birkerød, Denmark
 Tel: +45 4582 4440
 Fax: +45 4582 5550
 E-mail: jvl@jvl.dk www.jvl.dk

